

# International Education Journal



Volume 1 Number 3  
December 2000

Published by

Shannon Research Press  
Adelaide, South Australia  
ISSN 1443-1475  
<http://iej.cjb.net>



# International Education Journal

Volume 1, Number 3, December 2000



Welcome to the International Education Journal. This is a broadly based journal encompassing research and review articles. Education is interpreted in a wide manner and includes human development, learning, school education, formal and informal education, tertiary and vocational education, industry training and lifelong learning.

**Online** - While there will be a hard copy version of the journal it is intended that it will be accessed in almost all instances via the web.

**Peer Review** - All articles appearing in this journal have been subjected to a peer-review process.

**Copyright** - Copyright of material produced in this journal rests with individual contributors. Apart from fair use such as brief quotation for scholarly purposes, permission to use material in this journal should be obtained from the authors concerned.

The views and styles expressed in the articles in this publication are those of the individual authors and are not necessarily shared by the reviewers, the editors or the editorial advisory board.

Published by:  
Shannon Research Press,  
13 Endeavour Court,  
North Haven, SA 5018,  
Australia

Copyright 2000

Shannon Research Press  
ISSN 1443-1475

All rights reserved. Apart from individual use, no part of this publication may be reproduced in any form or by any means without prior written permission from the publisher.

Designed by Katherine Dix

Printed in Adelaide  
December 2000

## CONTENTS

<b>School governance: Research on educational and management issues</b> J. Ainley and P. McKenzie	139
<b>Global trends in education</b> C.N. Power	152
<b>Errors: What are they and how significant are they?</b> J.P. Keeves, T.G. Johnson and T.M. Afrassa	164
<b>The change of structural, perception and attitudinal dimensions in information technology implementation processes</b> I.G.N. Darmawan	181
<b>What the boys are saying: A project to examine the views of boys about declining rates of achievement and retention</b> M. Slade and F. Trent	201

### FREE Online Subscription

Subscription is available as a free service in online format only. Either complete the subscription form at: <http://iej.cjb.net> or email the [onlineeditor@iej.cjb.net](mailto:onlineeditor@iej.cjb.net). The reader will be notified of the latest issue and contents.

### Publication Frequency

It is intended that the journal be published three times per year. However given the electronic characteristics of online publishing it is not necessary to wait until a full journal is assembled prior to publishing. Articles once accepted in appropriate form may be published without delay. It should be noted however that in electronic format pagination may vary according to the parameters of the downloading computer. Alternatively the journal article can be downloaded in PDF format, in which case the original pagination will be preserved.

## Editorial Board

### Editors in Chief

Dr Reaburn Reynolds

Flinders University (Education)  
Bedford Park, South Australia  
Phone: 08-8201 2807,  
Fax: 08-8201 3184,  
reaburn.reynolds@flinders.edu.au

Prof John Keeves

Flinders University (Education)  
Bedford Park, South Australia  
Phone: 08-8201 2392,  
Fax: 08-8201 3184,  
john.keeves@flinders.edu.au

### Online Editor

Ms Katherine L. Dix

Flinders University (Education)  
Bedford Park, South Australia  
Phone: 08-8201 2105,  
Fax: 08-8201 3184,  
katherine.dix@flinders.edu.au

### Editorial Advisory Board

Prof Jonathan Anderson

School of Education  
Flinders University

Prof Bob Catley

Department of Political Studies  
University of Otago

Prof Kevin Marjoribanks

Graduate School of Education  
University of Adelaide

Dr Larry Saha

Department of Sociology  
Australian National University

### Aims of IEJ

The aim of the International Education Journal is to publish articles that possess one or more of the following characteristics or qualities.

1. The presentation of substantive findings which are of importance for policy and practice beyond the country in which the research was conducted.
2. The integration of education with academic disciplines such as anthropology, demography, economics, history, law, linguistics, philosophy, political science, psychology and sociology, or examines educational issues from the perspective of the disciplines or investigates issues at the interface between education and one or more of these disciplines.
3. The examination of educational issues from a cross-cultural or indigenous people's perspective.
4. The evaluation of educational policy or programs or the use of information technology of cross-national interest and significance.

5. The employment of advanced research methods and measurement procedures which are clearly explained.
6. The presentation of empirically or analytically based investigations of theory, models or conceptual frameworks in the field of education.
7. The syntheses of research findings from comparative and cross-national studies in education.

### Invitation

**Contributors** - Authors are invited to submit material to this journal. As a general guide articles should be not more than 5000 words. The journal may publish longer works such as theses or dissertations as occasional monographs. In every instance material must be received in publisher ready format. Full details of publication style and other requirements are set out under the heading Author Information.

**Publishers** - If you wish to have books or educational software reviewed and published in the International Education Journal please contact the editors.

**Reviewers** - If you are interested in contributing to the journal by writing a review article (500-1000 words) please contact the authors indicating your areas of interest. We look forward to hearing from you.

### Author Information

IEJ welcomes practical and research manuscripts that focus on educational issues, provide a clear purpose and depth of discussion, and are presented in a straight-forward style accessible to an international audience.

The initial submission:

- should be prepared using the downloadable Microsoft WORD97 template document (iejbase.doc), complete with layout styles, images and tables correctly positioned in the text
- images that are imported or inserted into the text from an external source as figures should be included as separate graphic files (either GIF or JPG format)
- should be forwarded electronically, either by:  
e-mail to: [onlineeditor@iej.cjb.net](mailto:onlineeditor@iej.cjb.net)  
or,  
on a 1.4MB 3.5 inch floppy diskette to: IEJ Online Editor,  
13 Endeavour Court, North Haven,  
SA 5018.

The editors reserve the right to return poorly edited or improperly formatted manuscripts. Hard-copy only submissions cannot be accepted or returned.

The manuscript should:

- show the article's title, authors' names, affiliation, and email addresses (these will be included on the online page), and postal address and telephone numbers (these will be removed from the final online page)
- abstract should not exceed 150 words
- paper should not exceed 5,000 words (20,000 for occasional papers)
- include an abstract of about 150 words
- include 5 keywords describing article
- be in final form ready for reviewing
- conform to the APA Reference System

General Principles for layout:

- Papers should be prepared using the template *iejbase.doc* with Microsoft WORD on Mac or PC
- Authors with WORD 98 or later and a basic understanding of web page construction should also save their paper in web format (*\*.html*) incorporating any hypertext features.
- Use end-notes, with one set of numbers running through the whole article.
- Use italics (not underline) for emphasis.
- Do not create additional headers and footers in the template document *iejbase.doc*, just modify appropriately.
- Do not use page numbers in text (web pages do not follow conventional page numbering systems).

If you have any questions regarding layout and presentation, please contact the IEJ Online Editor by email on: [onlineeditor@iej.cjb.net](mailto:onlineeditor@iej.cjb.net)

### FUIIE

The publishers have arranged for the Flinders University Institute of International Education to produce and host an electronic mirror site containing all material in the Journal, accessed free of charge. There are no restrictions on downloading or printing single copies. The electronic version also provides readers with a search tool.

# School Governance: Research on Educational and Management Issues

---

**John Ainley**  
**Phillip McKenzie**

Australian Council for Educational Research [ainley@acer.edu.au](mailto:ainley@acer.edu.au)

*In a number of countries the past 20 years have seen increases decentralisation of authority for a range of decisions to individual schools. A range of arguments has been advanced in support of decentralisation but a common belief is that shifting authority to schools will enhance the quality, effectiveness and responsiveness of public education. This paper argues decentralisation is not a unitary concept and can be applied to different elements of the teaching and learning environment: curriculum organisation, financial management, personnel management and resource allocation. Research that has investigated the impact of decentralisation itself on student learning outcomes has not revealed large effects. However, there appear to be greater impacts where decentralisation is implemented as part of a package of changes where the central authority has responsibility for defining curriculum frameworks, monitoring quality and intervening as necessary the results are more promising.*

Keywords: Decentralisation, Educational Administration, Academic Achievement, Outcomes of Education, Government School Relationship

## INTRODUCTION

Decentralisation of decision making, increasing local authority and enhanced autonomy of schools have been common features of recent changes in the organisation of public education in Australia and many other OECD countries. In Europe there have been major changes in the legislative framework for the provision of public education in England (1988), France (1983 and 1989), Italy (1997), Spain (1990 and 1995) and Sweden (1985, 1988 and 1991), and developments towards site-based management in North America and elsewhere. Site-based management has been documented in Canada (Brown, 1990), the United States (Herman and Herman, 1993), New Zealand (Wylie, 1995) and Australia (Caldwell, 1998). Whatever the political hue of governments in Australia and other countries, the last 20-30 years have seen substantial changes in the administrative, funding and supervisory relationships between central education authorities and individual schools and groups of schools. The common belief underpinning these changes is that devolution of authority to schools will enhance the quality, effectiveness and responsiveness of public education.

In some respects the moves towards greater school autonomy have proceeded further and faster in Australia than in most other countries. Somewhat ironically, the fact that Australian public school systems *are* highly centralised in regard to Ministerial political responsibility and sources of funding has meant that the changes here have tended to be more sweeping than in systems where political responsibility and funding sources for schooling are much more decentralised, such as in the USA. Australian public schooling is also interesting in the sense that it sits alongside a substantial non-government school sector (currently enrolling over 30 per cent of students) which provides a model of how decentralised schooling may work (although substantial elements of non-government schooling are themselves highly centralised) and which also is under pressure to be more accountable to government.

As anyone who has lived through the last decade or two of Australian public schooling would know, however, “decentralisation” is far from a being a unidimensional and uncontested concept. For example, depending on the state concerned, at any one time schools could be simultaneously experiencing greater autonomy in financial and staffing matters, and less autonomy in curriculum development and student assessment. In Europe too, behind the overall similarity in the trends towards devolution there remain substantial differences in the areas of decision making transferred from the centre to the school: organisation of curriculum; financial management; personnel management; and resource allocation. In addition Bottani (2000) notes that an increase in decentralisation to school sites in some areas of management has been accompanied by an increase in control by the centre in areas such as curriculum (eg. through national curriculum frameworks).

In this paper we will argue that is important for research on school governance to focus on the detail of decentralisation. To help understand and analyse the nature of decentralisation we use a framework based on a structure originally developed by the OECD. That framework is built around decision fields (organisation of instruction, planning and structures, personnel management and resource allocation), decision levels (national, state, intermediate and local) and decision modes. A framework such as this can help clarify deliberations about the appropriate levels of decision making for particular aspects of school governance. An awareness of the different dimensions of decentralisation can also aid interpretation of the somewhat contradictory research findings that have been reported from different settings on the relationship between “decentralisation” and educational outcomes. The presentation will argue that, for both educational research and practice, it is important to consider questions of school governance in relation to particular aspects of management rather than as a single dimension of decentralisation.

### **DIMENSIONS OF DECENTRALISATION**

In their cross-national review of policy and research on decentralisation within public education systems, Walberg et al (2000) identified 22 different definitions of the term, including: principals collegially share power with teachers; restructuring government to satisfy citizen needs and interests; and school-based decision making.

The framework developed by the OECD during the 1990s to guide its cross-national data collection and indicator development on the locus of decision-making authority in education systems provides a comprehensive means of capturing the various meanings attributed to decentralisation. The framework comprises six levels of decision (two levels were added in the late 1990s to the original four used in the early 1990s in order to better express relationships in federal and regional systems), four fields of decision, and three modes of decision. Each of these groupings in turn comprises a number of different sub-levels or elements. The framework is shown in Table 1.

The analysis by Walberg et al (2000) indicated that the 22 definitions of decentralisation they identified in various national research studies could all be encompassed within the OECD framework, which underlines its usefulness. Nevertheless, to apply the framework within countries like Australia some further disaggregation and elaboration could well be required to more fully capture the diversity of local circumstances. For example, in the dimension concerned with Levels of Decision it could be important to distinguish within the *School* level between formal levels of responsibility that may lay with the principal or School Council and actual location of decision making by senior teachers or groups of teachers. Similarly, the framework does not quite capture the situation that has been common in most Australian states whereby regional sub-units of central education departments exercise considerable authority over resource allocation but the regional offices do not really constitute territorial authorities or levels of government.

**Table 1. Dimensions of the OECD Surveys on Loci of Decision Making**

Levels of decision	Fields of decision	Modes of decision
<ul style="list-style-type: none"> <li>• <i>School, School Board or Committee:</i> school administrators and teachers or a school board or committee established exclusively for the individual school.</li> <li>• <i>Local Authorities or Governments:</i> the municipality or community that is the smallest territorial unit in the nation with a governing authority.</li> <li>• <i>Sub-regional or Inter-municipal Authorities or Governments:</i> the second territorial unit below the nation in countries that do not have a federal or similar type of governmental structure</li> <li>• <i>Provincial or Regional Authorities or Governments:</i> the first territorial unit below the national level in countries that do not have a federal type of governmental structure; and the second territorial unit below the nation in countries that have a federal or similar type of governmental structure</li> <li>• <i>State Governments:</i> The first territorial unit below the nation in federal countries</li> <li>• <i>Central Government:</i> all bodies at national level that make decisions or participate in different aspects of decision making</li> </ul>	<ul style="list-style-type: none"> <li>• <i>Organisation of Instruction:</i> bodies determining school attendance, student promotion and transfer, instruction time, choice of textbooks, criteria for grouping students, additional support for students with learning difficulties, teaching methods, assessments of students' regular work</li> <li>• <i>Personnel Management:</i> (principals, teachers, non-teaching posts): hiring and dismissal, duties and conditions of service, fixing of salary scales, influence over the careers of staff</li> <li>• <i>Planning and Structures:</i> creation or closure of school, determining programs of study for a particular type of school, definition of course content, setting of qualifying examinations for a certificate or diploma</li> <li>• <i>Resources:</i> (for teaching staff, non-teaching staff, other current expenditures, capital expenditure): allocation of resources to the school, use of resources in the school</li> </ul>	<ul style="list-style-type: none"> <li>• <i>Full Autonomy:</i> subject only to constraints contained in the constitution or in legislation outside the education system itself</li> <li>• <i>In Conjunction or After Consultation:</i> with bodies located at another level in the education system</li> <li>• <i>Independently but Within a Framework Set by a Higher Authority:</i> eg a binding law, a pre-established list of possibilities, or a budgetary limit</li> </ul>

Sources: OECD (1995); OECD (1998); Bottani (2000)

It is interesting to note, too, that the OECD framework makes no explicit mention of decision making by parents for example, as to where they enrol their children. In the case of Australia it could be argued that the removal of zoning restrictions on where parents enrol their children has been a powerful force towards greater school accountability and responsiveness over and above any other changes in the pattern of school governance. This is particularly so in a climate of generally declining school enrolments and increased competition among schools.

Nevertheless, the OECD framework is a useful mapping of the broad dimensions of the concept of school governance and the care needed in examining the detail of what is meant by decentralisation.

## **CHARACTERISING SCHOOL GOVERNANCE IN AUSTRALIA**

Sturman (1989) provides a useful analysis of the major changes in the focus of decentralisation in Australian government school systems in the decades of the 1960s, the 1970s and the 1980s. Simplifying his analysis somewhat, he argued that the 1960s were associated with structural pressures for change (government systems were growing very rapidly and becoming hard to manage from the centre) and changes in attitudes and values that supported greater teacher and student involvement in decision making. These pressures were also evident in the 1970s and during that time they were overlain with a stronger interest in redressing educational disadvantage and the benefits of local responses in addressing individual learning needs, as well as pressures to update existing curricula and to develop new curriculum areas. The 1980s were characterised by Sturman as a time for accountability, with the adjectives “rigorous”, “consistent” and “coordinated” replacing the earlier emphases on “flexibility”, “adaptation” and “participation”. The 1980s were a time of major reviews in most government school systems that attempted to develop stronger curriculum frameworks that to some extent moved the responsibility for curriculum development back from individual schools and teachers to central authorities. Towards the end of the 1980s the first of the state-wide assessment programs also started to appear, presumably partly in response to the demise of the inspectorate in most systems during the 1970s and early 1980s.

The processes of centralised curriculum control and tighter lines of accountability have continued into the 1990s, but with some interesting countervailing developments. First, in government school systems like Victoria significant responsibility for personnel matters (eg selection of principals) and operating budgets (initially responsibility for non-teacher expenditures, but now full global budgets) have been devolved to school councils and principals. Second, school accountability is now expected to be demonstrated outwards to parents and the local community as well as upwards to the centre. Third, considerable effort has been put into better equipping schools with the management tools and data to better exercise their responsibilities. Fourth, the 1990s have seen significant progress towards a more national approach to schooling as reflected in national qualifications frameworks, recognition of teachers’ qualifications across state borders, and equating of tertiary entrance scores.

In terms of the OECD framework used in Table 1 the period from the 1960s to the 1990s can be characterised as one in which State Governments changed from having virtually full autonomy over the four major fields of decision making about schooling, and schools and the national government had virtually none, to one in which the State Government, schools and national government to some extent operate in conjunction or collaboration in all four fields with the extent of decentralisation to schools varying according to particular elements within the broad fields.

The most recent data reported by the OECD on how the distribution of decision-making authority in Australian schools compared to that in other countries was derived from the 1995 Third International Mathematics and Science Study (TIMSS) conducted by the IEA. The data reported the perceptions of principals of schools enrolling 8<sup>th</sup>-grade students about where primary responsibility lay for a number of curriculum and school organisation decisions. Data were reported for 21 OECD countries (OECD, 2000).

A distinctive aspect of the perceptions reported by Australian school principals was the relatively high prominence given to decision making exercised being exercised primarily by Department Heads in the school. In the area of curricular organisation Australia was second only to New Zealand in the high proportion of principals reporting that Department Heads in the school had primary responsibility for “choosing textbooks” (88%) and determining course content (76%). In

most other countries Teachers were identified by school principals as having primary responsibility in these regards, which raises the interesting possibility that Australian schools may exhibit comparatively high levels of internal curriculum coherence. In regard to school organisation the Australian principals reported that Department Heads had primary responsibility for student grading policies (61%), placing students in classes (85%) and establishing homework policies (51%). In the latter instances in most other countries the primary responsibility was reported to be exercised by either the Principal or Teachers. These data reinforce the need for any schema of decentralisation to enable identification of different loci of decision-making responsibility within schools as well as between schools and other authorities.

### **IMPLEMENTING SITE-BASED MANAGEMENT**

Leithwood and Menzies (1998) review the literature concerned with the implementation of site-based management. They note other purposes for school-based management; to provide more direct forms of accountability, to provide greater discretion in the use of resources and to make more use of the professional capacities of staff. In addition they identify three forms of decentralisation or school-based management depending on where the locus of decision making lies. Administrative school-based management is aimed at is concerned with delegation of authority from the central office to the principal and is focussed on increased efficiency in the use of resources and on accountability through the principal. Professional control school-based management focuses on the role of teachers and decision-making structures within schools with the goal of increasing the efficacy of professional staff in schools. Community site-based management is concerned with accountability to parents and the community at large and often is associated with a curriculum that is thought to reflect more directly the values and preferences of parents. Leithwood and Menzies note the mixture of models in most administrative changes but emphasise that the differences in modes of decentralisation can have different expectations regarding outcomes. They observe that professional-control site-based management may have the greatest potential to impact on student learning.

Leithwood and Menzies (1998) argue that the potential for site-based management to impact on student learning is often blunted by problems of implementation. They analysed nearly 80 empirical and case studies of the implementation of site based management between 1985 and 1995. Overall they observe that whatever forms of site-based management were intended the result was often a variant of administrative control mode. This they argue is because the other modes of site-based management required internal change in schools and that this was not planned for and involved significant costs in terms of the time of principals and teachers.

The largest category of obstacles identified in the review concerned attitudes and beliefs. This includes concerns about the viability of the new approach and consequences for one's individual approach to work. Lack of knowledge, skills and behaviours (in terms of the requisites to implement new forms of management) was a frequent obstacle as was lack of opportunities (time and resources). Leithwood and Menzies note that these groups of obstacles are commonly mentioned in the broader literature on the implementation of change. Practitioners become overwhelmed at needing to maintain and change their organisations concurrently. In Australia, Sturman (1989) notes that the impact of the devolution of curriculum decision making in Australia had limited impact for a number of structural reasons and because the beliefs of teachers about the nature of knowledge were strongly established.

In general the conclusion from the analysis conducted by Leithwood and Menzies (1998) is that decentralisation to schools may have only limited impact on what happens in schools unless specific attention is paid to implementing within school change. They argue that the most

promising ventures in this direction model the within-school processes on the lines of high-involvement organisations.

## EVIDENCE ON LINKS BETWEEN SCHOOL AUTONOMY AND OUTCOMES

### Studies of School Effects

Many studies in education from the mid-1960s to the mid-1970s concluded that differences among schools had little real impact on student outcomes. For example the report on equality of educational opportunity in the United States concluded that *schools bring little influence to bear on a child's achievement that is independent of the child's background and general social context* (Coleman et al, 1966, p. 325). Other scholars reached similar conclusions. These conclusions about the effectiveness of schools were based on large-scale sociological inquiries with various units (often aggregated) of analysis and focussed on questions of equality of opportunity for various social groups. The studies often had fairly weak measures of school factors. Even though there were contrary interpretations of the same data which stressed that schools might indeed have an effect on student outcomes (Madaus et al, 1980), the overall the story was a pessimistic one.

In the late 1970s and early 1980s there emerged a body of research concerned with effective schools. It originated in a concern with equity; an intention to improve the achievement outcomes of students in schools located in poor inner-urban areas. These studies focussed attention on achievement test scores in literacy and numeracy as indicators of school effectiveness. Many of those early studies sought to identify schools which were “unusually” effective in terms of achievement in reading and mathematics and then to probe the sources of effectiveness, using case study methods and systematic comparisons (Teddlie, Kirby and Stringfield, 1989).

In recent times investigations of the effectiveness of schools have been based on studying the differences in student outcomes among schools. Where outcomes differ among schools, after allowing for different background characteristics of the students attending those schools and aspects of school context, it is taken as evidence that schools have contributed to those outcomes. One of the more important conclusions to emerge from recent research, and major reviews of research, on school effectiveness is that some schools are more effective than others (McGaw, Piper, Banks and Evans, 1992; Scheerens and Bosker, 1997; Teddlie and Reynolds, 2000). In other words differences among schools appear to be systematically associated with differences in student outcomes. That research has suggested that the differences among schools might be as substantial as differences in social background in shaping some important outcomes of schooling. There is now an emerging consensus that between eight and 15 per cent of the variance in achievement outcomes is associated with the school attended (Bosker and Scheerens, 1997).

### School Governance as an Element in School Effects

The recently published International Handbook of School Effectiveness Research (Teddlie and Reynolds, 2000) notes that school governance structures have been studied as context variables in school effectiveness (eg. private versus public, different types of church schools, different districts and school boards). Teddlie and Reynolds (2000: 184-185) conclude from this literature that the size of school effects “tend to be larger in schools that have governance structures allowing more control of their academic operations”. In other words, and not surprisingly, there is more variation among schools in devolved than among schools in centralised systems. However, in terms of the overall effect of school governance on student outcomes the research evidence is not extensive. A meta-analysis of school-based management in the United States in the 1980s revealed little impact (Malen, Ogawa and Kranz, 1990). Summers and Johnson (1998) point to the

problems that arise from the many meanings attached to terms such as site-based management and the limited number of studies that include a measure of student outcomes as well as measures of the extent of devolution of authority. More recently Walberg, Paik, Komukai and Freeman (2000) have drawn together results from a number of studies of decentralisation from a number of different countries. That review points to the range of different definitions of decentralisation and related views of its effectiveness. The authors conclude that despite the amount of policy interest in decentralisation its features have little influence on value-added learning. The review argues that classrooms and schools have more consistent effects on learning than how decision making is divided among levels of government. In fact they suggest that decision making by intermediate units is less effective than central control. Despite this picture of the effects of governance there remain important questions of articulation. In other words how does the pattern of governance of schools influence the all-important conditions in classrooms and schools? Grissmer, Flanagan, Kawata and Williamson (2000) analyse factors associated with improved scores on the National Assessment of Educational Progress in the United States. Those analyses point to improvements that link to policy changes and argue that the substantial improvements in North Carolina and Texas have resulted from “an integrated set of policies involving standards assessment and accountability”. Elsewhere the report identifies changes in school governance as a policy development but does not explicitly link those policies to the gains.

There is a number of problems in research on the effects of school governance. One is the lack of variation within systems of schools (schools within a system tend to have the same patterns of governance). A second is the confounding effects of other influences when comparisons are made between school systems (eg. in student background when comparing public and private schools). A third is that when changes are introduced in a school system other changes are made at the same time (eg. new quality assurance systems at the same time as devolved governance). These and other issues make the field a challenging one in which inferences are likely to be conditional and contested rather than clear and ambiguous. There are three main sources of research evidence that might inform deliberations about the effects of governance on outcomes: studies of changes that have been introduced in education systems, studies of differences between school systems within country contexts and studies of differences between corresponding types of school in different countries.

## **The Effects of Changes Introduced to School Systems**

### *The Chicago School Reforms*

Studies of changes in the governance of schools in the Chicago School District have been extensively researched with the results of that research being used to inform the progress of the changes that had been introduced. The first phase of the Chicago school reforms in 1988 involved decentralisation of authority to school sites. The second phase involved strengthening authority for accountability at district level while retaining devolved authority for operations in a Local School Council. Wong (2000) refers to this as an “integrated governance” which creates the appropriate balance of pressure and support to sustain improved outcomes. A longitudinal study of students progressing through school during the first phase of the reform indicated generally improved outcomes in elementary schools but mixed results across subject areas and cohorts (Bryk et al, 1998). Wong (2000) argues that that the stronger and more consistent improvement emerged in the second phase of the reforms when the district asserted a stronger role in monitoring, accountability and intervention.

*Philadelphia*

Changes in school governance in Philadelphia introduced during the 1990s involved decentralisation of decision-making (based around School Councils) but within a new curriculum framework and a program of monitoring outcomes in reading mathematics and science at several year levels. Phillips (1997) reports improvements in test scores in those areas but it is not clear whether the improvement resulted from the decentralisation or the monitoring program that was linked to a range of interventions in schools.

*Britain*

Since 1988 in Britain there has been an initiative towards locally managed schools and it has been possible for schools in Britain to operate independently of local authorities (as grant-maintained schools). There are conflicting claims regarding the outcomes from grant-maintained schools. Levacic and Hardman (1999) showed that grant-maintained schools had shown a higher level of improvement (in GCSE results) over a five-year period than locally managed schools but this was explained by their changing composition. When changes in composition of the student body was taken into account there was no difference in the levels of achievement of the schools.

*Charter Schools in the United States of America*

Gannicott (1998) outlines the growth in numbers of charter schools in the United States over the past five years. Charter schools are publicly funded but autonomously managed under a contract or charter. He notes that there is little systematic evidence of outcomes regarding charter schools despite a range of anecdotal comment and indications from individual schools (Finn et al, 1997). Favourable results in mathematics and reading have been reported for the Milwaukee Parental Choice Program in terms of school choice but only after three or four years in the program (Gannicott, 1998). In this exercise there was roughly random admission to the program for those seeking admission and there were statistical controls for the effects of family background and context.

*Schools of the Future in Victoria*

The *Schools of the Future* in Victoria involved a high level of self-management by schools within a newly articulated curriculum and standards framework and a program of quality assurance through school annual reports. As part of a formative evaluation study Principals in those schools responded to a questionnaire on which they expressed an opinion about the extent to which objectives of the program were being achieved (Caldwell, 1998). Analysis of those data suggest a number of associations with curriculum and learning benefits but it is not possible from these data to ascertain whether their have been measurable improvements in achievement.

**Differences between School Systems within National Contexts**

Some of the support for the view that outcomes are enhanced in a decentralised system of school management is drawn from considerations of differences between school systems.

*Public and Private Schools in the United States*

Gannicott (1998) discusses the analyses conducted by Chubb and Moe (1990) of achievement gains over the final two years of high school. The analysis utilised a composite index of student achievement in reading, writing, mathematics and science. Since initial student achievement was incorporated in the analysis the influences that were identified were influences on achievement gain. On the basis of those analysis (which included individual socioeconomic background and

school socioeconomic status) the authors concluded that school organisation (a measure of autonomy) had an impact on achievement gain over the two years. The measure of school organisation is closely related to school system differences. Chubb and Moe (1990) argue that the reason why private schools appear to be more effective than public schools is because of their organisational characteristics (that are linked to their autonomy). However, one should pause to consider that there may be other differences between the school sectors that impact on outcomes that have not been included in the analysis: motivation and parental expectations for example.

Gannicott (1998) also refers to a succession of studies of Catholic schools in the United States. There has been a succession of studies over many years of Catholic schools compared to public schools (Hoffer, Greeley and Coleman, 1985). Some studies examined the effects of Catholic and public schools using data from the High School and Beyond collection (Coleman, Hoffer and Kilgore, 1982; Coleman and Hoffer, 1987). The findings have reported higher achievement in Catholic schools in reading, mathematics and science overall and especially for minority students. In addition Catholic schools had lower rates of leaving school before the final year (Evans and Schwab, 1995). Subsequent studies using different techniques have argued that there was no significant difference between the school systems for white students but confirmed the advantage for minority students. These results have been often been interpreted as reflecting the effectiveness of a decentralised form of administration. However, other interpretations that may be linked to school organisation have also been suggested. Hoffer et al (1985) suggest that higher achievement results from placing students in academic rather than vocational programs (see also Lee, Bryk and Smith, 1993), providing more time in academic courses and assigning more homework. Rowan, Raudenbush and Kang (1991) suggest that Catholic schools appear to have more supportive administrative leadership, participative decision making and higher levels of staff co-operation. Lee et al (1993) interpret the differences in organisation between Catholic and public schools as reflecting a shared sense of purpose or community. It is possible that Catholic schools are more able to develop a unified sense of purpose because they are less subject to bureaucratic regulation and multiple goals or it may be that these features derive from other sources.

### *Other Studies of School Systems*

Scheerens and Bosker (1997: 278) conclude a review of studies of public and private school systems in a number of countries with the observation that in developed countries, private schools appear to be more effective, even in where both are financed by the state. They attribute this to the roles of parents in private schools as more active consumers of educational provision. McPherson and Willms (1986) found that achievement scores (after controlling for student intake characteristics) from Catholic secondary schools in Scotland were somewhat higher than those from non-denominational schools,. A study conducted in the Netherlands investigated the effects of different schools on participation in higher education and in the labour market (Van Cuyck-Remijssen and Dronkers, 1990). Although there were differences associated with school systems on entry to university those differences favoured public schools and there were no differences in university success or in the labour market. Toma (1996) reports an examination of mathematics achievement from the Second International Mathematics Study conducted in 1981. Because testing was conducted at the beginning and the end of the year it was possible to use a value-added model as well as make allowance for a range of student background characteristics. The model was used to estimate the differences in growth over one year for public and private schools in each country. The differences in gains between school systems in each of the countries vary somewhat. Toma argues that this reflects the degree of autonomy of private schools in those countries but it is possible that there are other differences in national contexts. Such results highlight the importance of differences in national contexts in interpreting school system effects.

### *Australian Studies*

There is little information from Australian studies that employ adequate controls for differences in intake characteristics. Analyses of the Social Science Survey suggested that, after controlling for other factors, private school students were more likely to complete secondary school and graduate from university (Kelley and Evans, 1999). Of course one might interpolate that this reflects one of the key unmeasured background influences: motivation and aspirations. Using the same data to focus on Catholic schools suggested that there was an educational advantage of attending a Catholic school compared to a government school after controlling for the effects of background (Graetz, 1990). Long Carpenter and Hayden (1999) conclude that the effect of attending a private school on school completion decreased from the 1980s to the 1990s but the effect on university participation remained evident.

### **Cross-National Comparisons**

Given that there are differences between countries in the management of the public school sector that more use has not been made of international data sets such as those from the IEA studies that would allow achievement to be related to organisational arrangements for schools in comparable sectors.

Schmidt and Prawat (1999) made use of data from the Third International Mathematics and Science Study to examine where decisions are made within different education systems. The purpose of the study was to seek information about those issues that were decided locally and those that were determined centrally. Across the education systems represented in that study they reported a uniformly high level of central control of both goals and the content of instruction with only methods of instruction and selection of materials being locally determined. The analysis reported by Schmidt and Prawat indicate that local control of important curricular decisions is not common in many countries and comparisons between countries does not provide guidance about the appropriate mixture of central and local authority in educational governance. Moreover the study does not relate patterns of governance to outcomes.

Scheerens and Bosker (1997: 279) conclude that there is no evidence that national systems where there is more autonomy for schools perform better in the area of basic competencies. In the Third International Mathematics and Science Study it was the more centralised education systems that performed relatively better. Although there is potential in international studies of achievement to examine the influences of school governance in the public schools that potential has not been used extensively. One of the problems is that such data usually incorporate only assessments at one point in time so that achievement growth cannot be assessed and used as the measure of student learning. Another is that there is a range of contextual information that needs to be included, as part of the analysis is wider than is typically collected or analysed. Notwithstanding those difficulties cross-national comparisons of public schools may provide a useful perspective on the impact of governance modes on student outcomes.

Of course there is a set of questions to be considered regarding the effects of patterns of school governance on the social distribution of educational outcomes to be considered in addition to effects on levels of outcomes. Whitty, Power and Halpin (1998) in a study of changing policies and practice in school governance in five countries conclude that there is evidence of wider disparities in educational opportunities in decentralised modes of governance but little evidence of general improvements in achievement. Analysis of data from international achievement studies would provide opportunities to test the effect of decentralisation on the distribution of educational outcomes.

## CONCLUSION

Research on school governance is concerned with more than where decisions are made. It is concerned with the package of arrangements that constitute the framework within which teaching and learning occurs. Elements of that framework include the way the curriculum is organised, financial management, personnel management and resource allocation. In an early part of these paper it was noted that decentralisation could occur with respect to any or all of these elements. Research that has linked decentralisation by itself to student learning outcomes has not suggested large effects. However, decentralisation is often implemented as part of a package of changes. Where this package forms part of an integrated governance structure in which the central authority has responsibility for defining curriculum, monitoring quality and intervening as necessary the results are more promising.

## REFERENCES

- Bottani, N. (2000). *Autonomy and decentralisation: between hopes and illusions. A comparative study of reforms in five European countries.* Paper presented at the Annual Meeting of the AERA, New Orleans.
- Brown, N. (1990). *Decentralisation and School Based Management.* Bristol, Falmer.
- Bryk, A. (1998). *Chicago school reform: Linkages between local control, educational supports and student achievement.* Paper presented at the Annual Meeting of the American Educational Research Association, San Diego.
- Caldwell, B. (1998). *Self-managing Schools and Improved Learning Outcomes.* Canberra, DETYA.
- Chubb, J. and Moe, T. (1990). *Politics, Markets and America's Schools.* Brookings Institute, Washington.
- Coleman, J. and Hoffer, T. (1987). *Public and Private Schools: The Impact of Communities.* New York, Basic Books.
- Coleman, J., Campbell, E., Hobson, C., McPartland, J., Mood, A., Weinfeld, F and York, R (1966) *Equality of Educational Opportunity.* Washington, DC, US Department Health, Education and Welfare.
- Coleman, J., Hoffer, T and Kilgore, S. (1982). *High School Achievement: Public Catholic and Private Schools Compared.* New York, Basic Books.
- Evans, W. and Schwab, R (1995). *Finishing high school and starting: Do Catholic schools make a difference? Quarterly Journal of Economics,* November.
- Finn, C., Vanourek, G., Manno, B. and Bierlen, L (1997). *Charter Schools in Action,* Final Report. [Online] <http://www.edexcellence.net/chart/chart5.html> [2000, August]
- Gannicott, K. (1998). *School Autonomy and Academic Performance.* Canberra, DETYA.
- Graetz, B. (1990). *Private schools and educational attainment: cohort and generational effects. Australian Journal of Education,* 34 (2).
- Grissmer, D., Flanagan, A., Kawata, J. and Williamson, S. (2000). *Improving Student Achievement: What NAEP State Test Scores Tell Us.* Santa Monica, Rand Corporation. [Online] <http://www.rand.org> [2000, August]

- Herman, J and herman, J. (1993). *School-based Management: Current Thinking and Practice*. Springfield, Thomas.
- Hoffer, T., Greeley, A. and Coleman, J. (1985). Achievement growth in public and Catholic high schools. *Sociology of Education*, 58 (1).
- Hofman, R. (1995). Contextual influences on school effectiveness: the role of school boards. *School Effectiveness and School Improvement*, 6 (2), 308-331.
- Kelley, J. and Evans, M. (1999) Non-Catholic private schools and educational success. *Australian Social Monitor*, 2, 1-4.
- Lee, V., Bryk, A. and Smith, J. (1993) Organisation of effective secondary schools, in: L. Darling-Hammond (Ed.) *Review of Research in Education*, 19, pp. 171-267.
- Leithwood, K. and Menzies, T. (1998). A review of research concerning the implementation of site-based management. *School Effectiveness and School Improvement*, 9 (3), 233-285.
- Levacic, R. and Hardman, J. (1999). The performance of grant maintained schools in England: an experiment in autonomy. *Journal of Educational Policy*, 14 (1), 185-212.
- Long, M., Carpenter, P. and Hayden, M. (1999) *Participation in Education: 1980-1994*. Melbourne, ACER.
- Madaus, G., Airasan, P., and Kellaghan, T. (1980) *School Effectiveness: A Reassessment of the Evidence*. New York, NY, Free Press.
- Madaus, G., Airasan, P., and Kellaghan, T. (1980) *School Effectiveness: A Reassessment of the Evidence*. New York, NY, Free Press.
- Malen, B., Ogawa, R. and Kranz, J. (1990). What do we know about site-based management: a case study of the literature. In W. Clune and J. Witte (Eds) *Choice and Control in American Education Volume 2: The Practice of Choice and School Restructuring*. London, Falmer.
- McGaw, B., Piper, K., Banks, D., and Evans, B. (1992) *Making Schools More Effective*. Melbourne, ACER.
- McPherson, A. and Willms, J. D. (1986). Certification, class conflict, religion and community: an explanation of the effectiveness of contemporary schools, in A. Kerkchoff (ed) *Research in Sociology of Education and Socialisation*, 6, 227-302.
- OECD (1995). *Decision Making in 14 OECD Education Systems*. Paris: OECD.
- OECD (1998). *Education at a Glance. OECD Indicators 1998*. Paris:OECD.
- OECD (2000). *Education at a Glance. OECD Indicators 2000*. Paris:OECD.
- Phillips, V. (1997) The role of accountability in student achievement. Paper presented to a seminar at Melbourne University.
- Rowan, B. Raudenbush, S. and Kang, S. (1991). Organisational design in high schools: a multilevel analysis. *American Journal of Education*, 99, 238-266.
- Scheerens, J. and Bosker, R. (1997). *The Foundations of Educational Effectiveness*. London, Pergamon.

- Schmidt, W. and Prawat, R. (1999). What does the Third International Mathematics and Science Study tell us about where to draw the line in the top-down versus bottom-up debate? *Educational Evaluation and Policy Analysis*, 21 (1), 85-91.
- Sturman, A. (1989). *Decentralisation and the Curriculum: Effects of the Decentralisation of Curriculum Decision Making in Australia*. ACER Research Monograph No. 35. Melbourne: ACER.
- Summers, A. and Johnson, A. (1996). The effects of school-based management plans. In E. Hanushek and D. Jorgenson (Eds) *Improving America's Schools: The Role of Incentives*. Washington, National Academy Press, pp 75-96.
- Teddlie, C. and Reynolds, D. (2000). *The International Handbook of School Effectiveness Research*. London, Falmer.
- Teddlie, C. Kirby, P. and Stringfield, S. (1989) Effective versus ineffective schools: Observable differences in the classroom. *American Journal of Education*, 97, pp. 221-236.
- Toma, E. (1996) Public funding and private schooling across countries. *Journal of Law and Economics*, 39 (1).
- Van Cuyck-Rejmissen, A. and Donkers, J (1990). Catholic and Protestant schools, a better choice in the Netherlands? *School Effectiveness and School Improvement*, 1 (3), 211-220.
- Walberg, H., Paik, S., Komukai, A. and Freeman, K. (2000). Decentralization: An international perspective. Paper presented at the Annual Meeting of the AERA, New Orleans.
- Whitty, G., Power, S. and Halpin, D. (1998) *Devolution and Choice in Education: The School, the State and the Market*. Melbourne: Australian Council for Educational Research.
- Wong, K. (2000). Chicago school reform: From decentralisation to integrated governance. *Journal of Educational Change*, 1 (1), 97-105.
- Wylie, C. (1995). *Site-based management: Some lessons from New Zealand*. Paper presented at the annual meeting of the AERA, San Francisco.

## Global Trends in Education

---

**Colin N. Power**

Graduate Department of Education, University of Queensland

### INTRODUCTION

In the Twenty-first century, nations will become both more competitive and yet more interdependent, and their future ever more dependent on the knowledge, skills and resourcefulness of its people, creating new opportunities and difficulties for education. I believe that the opportunities created by global processes will be actualised only if we continue to insist that education is a basic human right and to resist the tendency to reduce education into yet another market commodity. If we fail, I fear that our world will become increasingly unequal, competitive, polarised, conflicted and dangerous.

### GLOBAL TRENDS AND EDUCATION

There has been so much clamour about globalisation that I am loath to add to the confusion, but I will try at least to clarify my own position. First, 'globalisation' is a multi-faceted set of processes which include not only the changes which have flowed from the new information technologies and opening up of markets, but also new concepts which mean that 'shrinking space, shrinking time and disappearing borders are linking people's lives more deeply, more intensely and more immediately than ever before' (UNDP, 1999, p.1).

Secondly, these global processes will not only make our societies increasingly multicultural and ever more intercultural as the interactions among cultural groups intensify, but also they will force shifts in our educational and development priorities as we assume multiple cultural identities. The major battle in the Twentieth century has focussed on the right of everyone to education as set out in Article 26.1 of the Universal Declaration of Human Rights, but during this century I believe that the struggle will be about the purposes of education for all. Whereas education must and should contribute to the productive life of every society, its fundamental purpose is clearly set out in Article 26.2 of the Declaration: 'Education shall be directed to the full development of the human personality and to the strengthening of respect for human rights and fundamental freedoms. It shall promote understanding, tolerance and friendship among all nations, racial and religious groups.'

My third point is that while there can be no doubt that the destinies of individuals, cultures and nations are being increasingly shaped by the decisions and actions of global players, globalisation is neither new (cf. great religions, empires of the past).

Fourthly, globalisation brings with it a mix of opportunities and threats for every nation, culture and educational system. On the one hand, the removal of barriers and new technologies create new possibilities for intercultural exchange and dialogue, but on the other, we face the danger of a new global imperial regime in which one political, economic and communication culture is unilaterally favoured over all others.

The global political and economic forces which lead to the collapse of the communist states can also unleash latent linguistic and racial tensions in states previously held together by force. More

generally, global forces may contribute to the undermining of what Gunter Grass calls the 'Kultur-nation,' the core values of the cultural, social and educational system of nations necessary for social cohesion and national identity. Global forces may liberate and empower people from all cultures and nations, but only if we use our new tools to empower the poor, to strengthen inter-cultural dialogue and to enable all cultural groups to participate in decisions affecting their lives.

The 1999 UNDP Report warns 'When the market goes too far in dominating social and political outcomes, the opportunities and rewards of globalisation spreads unequally and inequitably – concentrating power and wealth in a select group of people, nations and corporations, marginalizing others... If global opportunities are not shared better, the failed growth of the last decades will continue.' The challenge, it suggests, is to find the international institutions and rules for stronger governance to be raised to ensure that 'globalisation works for people - not just for profits.'

### **Inequality and polarisation**

At least three global trends pose challenges for education in the Twenty-first century and will make the task of learning to live together ever more important and challenging: inequality, population movements and the new information and communication technologies.

UNDP and others have warned that globalisation is increasing the gap between the rich and the poor, between the connected and isolated cultural groups. Inequality **within** countries certainly has increased dramatically over the past 20 to 30 years. As measured by the Gini co-efficient, the greatest income inequalities are in Latin America (especially in Brazil and Paraguay), while the most dramatic rises since the 1980s have been in Eastern Europe and the CIS countries. Associated with these gaps is the upsurge in violence, crime, corruption and even genocide. Among the OECD countries, UK, USA and Australia show the greatest gaps between the richest and poorest 20 per cent of the population, with the UK registering an increase of over 30 per cent in inequality in disposable income in the 1980s.

Inequality **between** countries has also increased dramatically this century, the income gap between the fifth of the world's richest countries and the fifth living in the world's poorest jumping from 11:1 in 1913, to 30:1 in 1960, and to 74:1 in 1997. Thus today more than one quarter of the population, some 1.3 billion people live, in abject poverty on incomes of less than \$1 day, while the assets of the three richest people in the world exceed the combined GNP of all LDCs. Despite the commitments made at Jomtien, Beijing and Copenhagen and the rapid increases in GNP per capita within the OECD countries, there has been a dramatic decline in aid provided for developing countries since 1992. Private foreign investment and loans have replaced aid, but the UNESCO-ILO studies of structural adjustment show the burden of debt falls most heavily on the public education and health services available to poor and marginalised groups. The research clearly shows that the greater the inequality within a country, the greater the suffering of the poor and the greater the marginalisation of minority cultures.

### **Population Movements and Cultural Diversity**

Global forces are also leading to increasing population movement and thus to an exponential increase in intercultural interactions and exchanges. Most nations have long been a mix of cultures, and after years of struggle, the various tribes and cultural groups that now make up modern democratic states have learned to co-exist, even to celebrate difference as a fact of life. But as the extent of intercultural mixing and exchanges increase, we will face new challenges in learning to live together.

Whereas globalisation is opening doors for a highly mobile, highly skilled international elite, it seems to be closing them for many others who will either seek to escape or remain locked in poverty. An estimated 130-145 million people now live officially outside their countries of origin, and there are at least as many illegal migrants. And over 23 million refugees struggle to survive: lacking papers, illegal immigrants, refugees and displaced persons face not only discrimination and exploitation, but also denial of human rights, including the right to education for their children. The sheer numbers of 'others' seeking a better life in another land creates irrational fears among the inter-culturally illiterate, fears too easily exploited by a racist far right.

Throughout human history, the majority of people lived in rural areas. But global forces are also accelerating the process of urbanisation. The year 2000 marks a divide from a predominantly rural world to one where the majority of people now live in cities. Of the more than 400 cities with over 1 million inhabitants, 28 are mega-cities with populations of over 8 million, two thirds of which are in developing countries. In the latter, over one third are under 14 years, very poor and make up the bulk of the 30 million or more 'street children.'

The renewed concern for lifelong education stems from such rapidly changing global realities. One can no longer learn enough to be a fully functioning member of a society in one's youth. Extended life expectancy coupled with dramatic changes in economic, social and cultural situations mean that both individuals and societies must continue to learn – or be left behind and become marginalised.

### **New information and communication technologies (NICT)**

The most visible symbol of globalisation has been the spectacular development of information and communication technologies and the creation of planetary networks with no structured organization or centralised management. The NICTs constitute an extra-ordinary resource base for the storing, dissemination and sharing of information, and strengthen intercultural exchanges and democratic participation. They do offer new possibilities for providing access to education for large numbers and isolated communities with economies of scale, multiple channels of communication, visualisation and simulation, and powerful means for the exchange, processing and storage of information. While enhancing the free flow of information, the very openness of our new communication systems make money laundering and dissemination of paedophilia and the culture of violence and racism easier. In the absence of controls, education systems can be expected to be called upon not only to help equip the young with the skills needed to use new information and communication tools but also to promote moral development and to make wise choices.

The second issue of concern relates to the impact on cultures and languages of new technologies and media. In theory, the new tools are neutral – if we invest wisely, NICT can help preserve threatened languages and cultural products and promote inter-cultural learning and understanding. Amid the multitude of websites and programs that celebrate travel, adventure and nature, we can find some which do attempt to build a deeper understanding of the cultures of others. NICT also open new opportunities for cultural minorities to interact in their own language and to support multi-lingual instruction. But currently the production of world's cultural 'exports' is dominated by a handful of extremely powerful and wealthy global magnates: 60 per cent of the Internet hosts and 83 per cent of the usage of the net are in the USA, and only 11 per cent is outside USA and Europe. Global monopolies controlling NICT may accelerate the homogenisation of the world's cultures and the extinction of many of its 6,000 languages.

## GLOBALISATION AND EDUCATION

### How will these global trends affect education?

In part, the answer may lie in existing trends in the delivery of educational programs. Educational programs cannot operate without educational materials and equipment (or 'goods') and in the absence of quality educational 'services.' Increasingly educational goods and services are being privatised. The Education and Training industry is now North America's second largest accounting for nearly 10 per cent of GDP. It is also the fifth largest service export in the USA (and seventh in Australia). Of the \$26 billion spent on educational goods and services in 1997, \$2.1 billion was for the web and about \$1 billion for software. For other OECD countries, the export of textbooks and services is also big business: in 1997, the UK exported over \$114 million worth of textbooks. Worldwide, the market for educational software now stands at over \$4 billion.

In a highly competitive and polarised world, there has also been a significant growth in the 'shadow education system' – the world of private tutoring: more than half of the students in secondary school receive tutoring in countries like Japan, Mauritius and ROK. In ROK, spending on private tutoring in 1996 was half as much again as public expenditure. Such growth seems to be a social response to inadequacies in government support for education, both in quantitative and qualitative terms, and can only lead to further exacerbation of inequalities and polarisation.

If current global trends continue, commercial activity in educational goods and services can be expected to grow substantially and education itself will become more 'globalised.' Highly capitalised educational publishers are shifting from marketing individual titles to marketing services to local publishers, while modern testing agencies are following a similar path. Standards for educational performance are becoming international as we have seen from OECD's *Education at a Glance*. The student body, faculty, courses and teaching provided by major universities are all being increasingly 'internationalised.'

### Globalisation and the right to basic education for all

Over the past two years, UNESCO and its partners (mainly UNICEF) have worked with 180 countries to assess their progress towards basic education for all (EFA) since 1990. Our statistics (UNESCO, 2000) show that most developing countries are making steady progress towards the goals of universal primary educational and reducing adult illiteracy, and that despite their limited resources, some developing countries (eg. Bangladesh) have made surprisingly good progress.

The quest to provide education for all has made little headway in countries ravaged by armed conflict, crippling debt and rapid population growth. In particular, the data show a worrying increase in the number of out-of-school children in the poorest countries, especially in Sub-Saharan Africa. Over the past decade, public expenditure for primary education in the LDCs remained static at about \$20 per pupil, while among the developed countries it rose to well over \$5000. In 1980, expenditure at the pre-tertiary level in the developed countries was 37 times higher than that of the LDCs: in 1997, it was 137 times greater. Education may be the key to poverty alleviation, but the education offered to the poor and in poor countries is one of the first victims when resources are being cut. Unless the global forces impacting on these countries and their internal situation changes dramatically, our estimates indicate they will fall further behind during the next decade.

While most countries have been able to keep pace quantitatively with the growth in numbers, few countries have been able to find the resources to provide a quality education for all. If anything, the quality of the education offered to the masses has suffered. For example, the picture emerging

from the analysis of the situation in Central and Eastern Europe reveals that the transition to a market economy has been extremely difficult for most countries in the region, the economic downturn precipitating cuts in educational expenditure and with that a deterioration in the conditions for teaching and learning, to growing inequality in education and high drop-out rates, especially in rural areas.

The evidence also suggests that even in the rich countries, increases in income inequality are associated with increases in education and social inequality. For example, not only does the UK have one of the largest income gaps among OECD countries, it also has the highest proportion (19.4%) of young people aged 16-19 years who are neither attending school nor employed, higher than Italy, Spain or Greece and roughly five times that of Denmark and Germany. The concerns about the quality of education expressed by the Heads of Government at the G-8 summit in Koln are predominantly related to this 'underclass' of disadvantaged young people most of whom leave school early, are functionally illiterate, and whose anti-social behaviour at school and in the community increasingly constitutes a threat to security and quality of life of others.

The cumulative social and educational effects of disadvantage have been well documented. The research shows that the impact of disadvantage on a particular child's education and subsequent behaviour depends on the cumulative effects of several risk factors including poverty, family breakdown, sustained patterns of impaired child-parent relationships, instability and disruption in key developmental contexts such as the family and school. The research suggests that irrespective of cultural context, it is difficult for families and schools to maintain the sustained care and interaction needed by a child to develop in conditions of poverty, conflict and constant change.

There have been many attempts to ameliorate the effect of disadvantage on educational opportunities. Mortimore and Whitty (1997) outline four: one based on the concept of meritocracy, one on the use of compensatory mechanisms, one on the creation of intervention projects, and the last, change through school improvement. The first emphasises **competition**, but the evidence show that although it works for a few (as many of us here can attest) it does nothing to improve the situation of those left behind – be they individuals, communities or countries. **Compensatory measures** may target individuals or families (eg. school meals), disadvantaged schools or groups (eg. Aboriginal Schools) or, at the international level, countries or even regions (eg. UN Special Initiative for Africa). In general, these are somewhat more effective, but targeting is not always easy and the root causes may remain untouched. **Intervention** projects such as *Headstart*, *Success for All* and the *Reading Recovery Programme* do seem to help combat the individual consequences of disadvantage but none of these remedies seem to be effective in altering the overall patterns of inequality in education. The roots of school **improvement** lie in the research on school effectiveness. This approach places the responsibility for change in the hands of the school and its community and the evidence suggests that when committed and talented school heads and teachers work in partnership with parents and the community even in disadvantaged areas, schools can improve.

Of course, it is not surprising that a strong negative correlation between most measures of social and cultural disadvantage and educational outcomes persist. Even a cursory glance at the league tables (cf. IEA, *Education at a Glance*) shows that schools and nations at the top are invariably those of the rich, and those at the bottom the most disadvantaged. Whatever changes are made at the school level or in the education systems of poor countries, their efforts will be constrained to the extent which inequalities within and between countries are structural and powerful mechanisms are maintained to reproduce existing hierarchies, and to the extent that 'social capital' continues to decline as relationships and supportive social networks collapse. The situation has been made worse by policies at national and international levels which deny the right of all to a

decent education and thereby undermine the principle that education is a public good and the responsibility of the whole society, especially of governments.

If we are to overcome disadvantage at the individual, national or international level, we need education programs which respect the cultures and address the realities of the families and children to be served and give priority to the alleviation of poverty and building support structures for families and nations in difficulty. The stark facts on growing inequality and polarisation presented above drive home the reality that it is simply impossible to improve access to education or the quality of the education in poor countries without extra resources, and that within countries extra resources must be found to improve the quality and functioning of schools, families and communities, particularly those located in disadvantaged areas.

But from where must these resources come? In the end, governments and international organisations (public and private) must assume their national and global responsibilities and reallocate resources to meet targets (eg 0.7 per cent for aid, 6 per cent plus of GNP for education etc) – even if that means taxing the rich, cutting arms expenditure or putting people before profits.

If we do not assume a new path, life will be particularly difficult during the Twenty-first century for the already disadvantaged. At the World Conference on Education for All (Jomtien, 1990), we insisted on meeting the basic learning needs of all, the emphasis being on learning achievement, not merely attending school. But acquiring the knowledge and skills needed to participate in the life and work of communities in the Twenty-first century is possible only if the essential conditions for learning are present in the formal and non-formal education programs. In the schools serving the poor and marginalised, these conditions are absent. Children cannot be expected to learn or to stay in school if they are sick, hungry and exhausted, if the school is overcrowded and unsanitary, if there are few or no books and teachers are unpaid and unqualified.

At best progress towards the alleviation of poverty will be slow if the present international economic and political order remains unchanged – if the poorest countries and groups are locked into a seemingly endless downward spiral of poverty, debt, conflict and misery and if inhuman traffic in weapons, drugs, arms, women and children continues unchecked. Education may be the key to the alleviation of poverty and to sustainable development, but not if the global economic order leads us to high quality private education for an elite and a poorly funded and inferior public education system for the masses. There will be a global crisis in education if we allow our market forces to polarise the world of education, internationally and nationally.

### **Globalisation and Higher Education**

Today, global wealth is concentrated less and less in factories and the land, and more and more in knowledge and skills. In the USA human capital is now estimated to be at least three times more important than physical capital. Participation in the rapidly changing knowledge society of the Twenty-first century demands new knowledge and skills and learning throughout life, and higher qualifications than ever before. As a result, the demand for higher education is growing constantly, higher education systems are under great strain to cope with dramatic increases in numbers without a commensurate increase in public funding. In many countries, expansion, both public and private, has been ‘unbridled, unplanned and often chaotic’. The results – deterioration in average quality, continuing inter-regional, inter-country and intra-country inequalities, and increased for-profit provision of higher education – could have serious consequences’ for developing countries and disadvantaged groups and the very concept of the ‘university.’

The World Conference on Higher Education (Paris, 1998) sought to ‘set the direction needed to prepare higher education for the tasks that await it in the Twenty-first century, and to help

mankind and the community of nations to strive out towards a better future, towards a world more just, more humane, more caring and more peaceful' by establishing a few key principles and priorities for action. The Conference showed the need to strengthen the traditional research and specialised teaching functions of the university, while at the same time to insist on its intercultural and international mission of higher education in the Twenty-first century.

Globalisation processes have led to an unprecedented demand for access to higher education while at the same time most governments are unwilling or unable to provide the necessary support to public institutions. Thus the dramatic growth in private and open higher education, the financial and identity crisis facing universities worldwide, and the intense and increasing competition for overseas students among the big league of internationalised universities and for adult learners from open and virtual corporate universities. In this context, I would hope that governments see beyond the immediate and understand that within the walls of the University there is a treasure within.

### **Globalisation and Teacher Education**

The Delors report (UNESCO, 1996) sets out an agenda for the future which implies that significant changes are needed in pre-service teacher education programs if we are to select and prepare a new generation of teachers equipped with the knowledge, skills and values to help their culturally different and their socially disadvantaged students to learn, to resolve conflicts peacefully, to respect each other's dignity and cultures, and to become socially responsible citizens. What emerges from the research is that teacher education which follows the 'Do as I say, not do as I do model' has to be replaced by one which sees learning to teach as a deeply personal activity in which includes activities designed to develop sensitivity to cultures, languages and lives of children coming from different social and cultural groups, and which provides constant and significant support, working with cohort groups, and a systematic long-term message which provides guidance and direction for personal development.

The direction and culture of educational research must also change if we are to reform educational policies, established practice, curricula and teaching materials in ways which facilitate intercultural learning and ameliorate the problems created by disadvantage and discrimination in education and society. For example, there is a great deal that we do not know about the impact of international and government policies what is happening in our multicultural schools and universities; about the content and processes of education in traditional and contemporary cultural contexts; about the conditions under which intercultural learning and conflicts are resolved peacefully in different settings; about how best to select, prepare and support teachers and communities to cope with the realities and contradictions created by shifts in population, technology and policy; about the effectiveness of different approaches to combating violence, racism, substance abuse and suicide in our schools and universities.

Another research agenda for the Twenty-first century relates to the impact of different types of student and faculty exchange programs, citizenship education, interactive multimedia packages and the web on intercultural sensitivity and the conditions under which various types of learning experiences transfer into acceptance of difference and tolerance in one's own community, school or university.

### **INTERCULTURAL EDUCATION IN THE TWENTY-FIRST CENTURY**

To return to my central theme, global trends mean ever greater mingling of cultures and thus learning to live together, cultural identity and inter-culturality will become priority issues. Given the long history of violence as a means of resolving conflicts among cultural or religious groups,

the Delors Report placed learning to live together not simply as one of the four pillars of education for the future, but as the greatest challenge facing education. It insisted that every national education system must give priority in the Twenty-first century to learning to live together ‘by developing an understanding of other people and an appreciation of interdependence – carrying out joint projects and learning to manage conflicts – in a spirit of respect for values of pluralism, mutual understanding and peace.’

The Delors Commission met in a context in which many of the former communist states were falling apart: cohesion was imposed by an all powerful state apparatus rather than being the product of a participatory and educational process for building unity in diversity and for resolving conflicts. Even in the west, social cohesion seems under threat from a polarised and at times violent ‘underclass.’ For the Commission, the most acute crisis facing many countries is that of social cohesion, a crisis fuelled by growing inequality, poverty and exclusion, and a sense of ‘social crisis compounded by a moral crisis and the spread of violence and crime.’ Its hope for a better future rests with the type of education which promotes cohesion while striving ‘to take the diversity of individuals and groups into consideration while taking care that it does not itself contribute to social exclusion.’

### **How do education systems respond to ever increasing cultural diversity?**

In every country, one of the prime functions of education has been that of building a social cohesive society – one held together by shared values, purposes and activities. While economic growth often seems to be driving government policy, building social cohesion still remains one of the main purposes of public education, and particularly as our societies become ever more multicultural.

Historically, at least four different approaches to cultural diversity have emerged: (a) **assimilation**: imposing a common nationality (b) **melting pot**: gradually developing a national culture (c) **differentialist**: developing a common nationality but minimizing interaction with and among minority cultures, and (d) **multiculturalism**: developing unity within diversity.

Until recently, most national education systems were designed to more or less impose one culture – usually that of the dominant race, class or political party or colonial power. While there has been almost as much backsliding as progress, countries like Australia, Canada and New Zealand are beginning to understand that their diversity of cultures is a treasure within and not a threat to social cohesion – provided that the rights and cultures of all groups are respected.

UNESCO’s constitution stresses both the ‘fruitful diversity of cultures,’ and ‘the intellectual and moral solidarity of mankind.’ In a globalised world, we all must face the problem of reconciling the ideal of respect for diversity with concerns for societal cohesion and the promotion of universally shared values and norms.

Even in well-established democracies, the will to learn to live together in a society with increasing cultural, religious and racial diversity is not assured. At first, immigrant cultural groups and the establishment tend to live out their separate lives, co-existing with limited interaction or understanding of each other in a society that is multi-cultural only in the demographic descriptive sense. Yet as nations become more multicultural, the intertwining of cultures leads to specific types of programmes and policy initiatives designed to respond to and manage ethnic diversity. It was in this usage that ‘multiculturalism’ first gained currency after it was recommended in the 1965 Canadian Report on Bilingualism and Biculturalism.

In the normative sense, multiculturalism represents a position about the place of cultural identities in contemporary society, stressing that acknowledging the existence of ethnic diversity and ensuring the rights of individuals to retain their culture should go hand-in-hand with enjoying full access to, participation in, and adherence to principles and values of the society. Nations adopting a multicultural approach to education have all sought to develop programs in which children and adults have opportunities to develop to a reasonable level of competence, both the national language(s) and their mother tongue, and an understanding of the major cultures (language, literature, history, religious values, and so on) of the nation. Participation in the multicultural knowledge society of the future will demand even higher levels of language competence and cultural sensitivity as the world shrinks. Thus progressively we can expect language policy to include elements of plurilingualism, NICT and lifelong learning. Thus in April 2000, the US Secretary of Education (Richard Riley) proclaimed: 'It is high time we began to treat language skills as the asset they are, particularly in this global economy. ...Our nation can only grow stronger if all our children grow up learning two languages....Our global economy demands it; our children deserve it.'

Countries adopting a multicultural approach generally acknowledge the need for greater knowledge and understanding of the major religions and other cultures and nations, their languages, history and values, and they increasingly employ staff from diverse ethnic backgrounds. The experience that has accumulated in these countries shows that neither special language programs nor educational programs may, in themselves, be sufficient to ensure equality in participation or mutual respect and understanding. The effectiveness of their policies for managing cultural diversity depends not on any one program of policy initiative but on their cumulative effect. What has also become increasingly clear from a range of studies of social justice initiatives is that there is a need to change the way in which the system and its institutions relate to its students.

### **UNFINISHED NATIONAL AGENDAS**

Turning now to some of the issues to be resolved in the future, in South Africa after apartheid, the task was seen as one of questioning and transforming the canons, assumptions and purposes that underlie the curriculum, the assumption being that prejudicial attitudes and behaviours, if learned through the medium of socially constructed culture, must of necessity be deconstructed and reconstructed through the process of multi-cultural education. The emphasis is not so much on creating a nation but a civic consciousness, with overarching or generic common ideals that are unifying and to which all citizens can subscribe. The task of reconciling national unity with cultural diversity in South Africa is made more challenging by the history of socio-cultural violence and abuse of human rights, regional and tribal claims to autonomy and the influx of migrants, but unlike some other ethnically diverse African countries, ethnic diversity is not seen as an obstacle in the reconciliation and reconstruction of national unity but rather as its fundamental and necessary ingredient.

For countries in transition to an open society, the problem of learning to live together is significantly different than under a highly centralised and powerful Party/state. As in South Africa, there is the problem of deconstructing the culture of the state and of the educational apparatus that supported it, and building a new civic consciousness and/or a new nation through education. Countries like Hungary have moved towards a performance-based curriculum in which performance standards are 'inspired by democratic values' which give equal weight to interests of the individual and the wider community. The origins of these 'standards' lie in the need for social cohesion within the nation, integration with the European union and world-wide integration on the one hand, and individual (eg career orientation) and local needs (eg. ethnic minorities) on the other. As in the UK and the USA, there has been an upsurge in interest in developing citizenship

education programs in many countries in transition, in most cases with considerable emphasis on human rights and tolerance as universal values that are at the heart of intercultural education. The recent UNESCO-Council of Europe Conference on civics education in Poland (Warsaw, December, 1999) showed considerable efforts are being made to build unity within diversity, but that it is never easy (even in Australia) to draw a line between the need for a national culture and the rights of local minorities.

Since the signing of the Dayton Peace Accord (December, 1995) the three main ethnic groups in Bosnia Heregovina have been using different curricula and textbooks in three regions in which they are in a majority. The content of these textbooks raises concerns about whether they would increase ethnic divisions, exacerbate differences and prevent social cohesion: the approach is certainly not one designed to promote critical thinking, tolerance or inter-cultural understanding. Certainly there are many examples of xenophobia, ethnic bias and extremism in the texts, but so far, despite all our efforts, the three groups refuse to work together on the reform of history teaching methods and textbooks: the region needs a textbook policy which follow the criteria and guidelines for the elimination of racism established by UNESCO.

### **Racism, Discrimination and Protection of Minorities**

The UN Sub-Commission on the Prevention of Discrimination and Protection of Minorities regularly reports on current trends in racism, racial discrimination, intolerance and xenophobia. It notes with alarm the rise in serious incidents attributable to these phenomena especially in Europe and the tendency to deny the existence of malignant processes in one's own nation, community and life. It warns of the emergence of neo-racism not grounded on biology but on anthropology and of the dark side of an excessive ideological commitment to the virtues of difference which may lead us to believe that different cultures are incapable of learning from each other.

Ignoring the psychology of racism, our schools, universities, media and national leaders have intensified the problems. If OECD countries had expanded their vision of social cohesion, they may well have profited more from the opportunities presented by the end of the Cold War and globalisation. Recognition of the problem of neo-racism and wide public education about the psychology of racism and the impact of the confusion of identities which is taking place in a changing world should make it possible for leaders and educators alike to summon into the public forum what Abraham Lincoln called the 'better angels of our nature.'

In no field of education does the issue of intercultural education as a human right have more poignancy than with respect to the rights of indigenous peoples whose languages and way of life is seriously threatened by globalisation and whose right to choose the form of education appropriate for their children (as set out in Article 26.3) has so often denied by assimilation policies. Only recently has Australia acknowledged the existence of the 'stolen generation' of aboriginal children who were removed from their families between 1910 and 1970 to attend religious or state schools. The broad international consensus that has emerged over the past 20 years on the rights of indigenous peoples has certainly played a key part in changing policy and legislation in at least 30 countries. While it would be fanciful to assume that these changes have eliminated centuries of injustice, prejudice and disadvantage, there is a growing acknowledgement, even appreciation, of the diverse cultures that make up national and global societies. Concurrent with this change have been significant changes within many indigenous communities in some cases a veritable renaissance among indigenous peoples in their cultures, languages, histories and traditional ways of learning.

Article 15 of the draft UN Declaration on the Rights of Indigenous peoples provides the right to full access to all levels and forms of education of the State, and the right of indigenous peoples to establish and control their own educational systems and institutions. The aboriginal peoples with whom Bob Teasdale and I worked with while I was at Flinders University sought nothing less than what they called two-way schooling – they recognised the need for the 'white fella stuff' because they very much want to participate fully in decisions being made outside their tribal lands which are affecting their lives, but at the same time wanted to control 'their own stuff', the key elements of their own cultural identity. They must live in two worlds and resolve the inconsistencies between their traditional cultural roots and those of the dominant culture.

### CONCLUSION

The effective functioning of families, schools and educational systems is sensitive to the existence of supportive public policies at the community, national and international level: it has been the poor and marginalised cultural groups who suffered the most from the global economic and political ideologies which led to the imposition of the structural adjustment, privatisation and cost-sharing programs which they could ill afford and which have led to a deterioration in the education available to their children. As the **World Education Report 2000** asks: 'If selected economic or other principles are to be given priority over principles which are embodied in one or more of the rights proclaimed in the Declaration, especially the right to education, how can it be convincingly explained to young people that such rights, indeed any of the rights proclaimed in the Declaration, are 'inalienable?'

The responsibility for respecting human rights and for setting the framework for the educational reforms needed to actualise a shared national vision of education for the Twenty-first century rests first and foremost with governments. The pattern of public expenditure and taxation does have a significant effect on poverty reduction and on the quality and inclusiveness of the education available to all groups in a multicultural society. The research (DFID, 1999) does point to the types of international and national educational policies, schools and educational programs necessary to overcome social and cultural disadvantage. While we need more ethnographic research on intercultural learning, we also need to put the research evidence on the table to ensure that governments do assume their responsibilities to ensure a just distribution of the benefits of globalisation within and among nations – otherwise, the rich will get richer (and meaner), the poor poorer (and more desperate), and our world ever more polarised and insecure.

The rise of the far right, racism, anti-semitism and one-nation agendas is a product of the fear of large population inflows interacting with ignorance of the other which have created so many conflicts and abuses of human rights in the past. As nations and cultures become ever more intertwined, it becomes ever more imperative that education systems develop policies and programs to counter the resurgence of discrimination, racism, ethnic violence and xenophobia which has erupted at the close of the Twentieth century. For both the dominant and minority cultures in a multicultural world, learning to live together must become a two way intercultural process – for it demands that each learn about, understand and respect the culture of the other, accommodate differences and resolve contradictions and conflicts peacefully and democratically. As I (Power, 1999) have argued elsewhere, it is also vitally important that educational reforms systematically focus on creating unity within diversity by developing the basic human values which underlie most cultures and major religions and are embodied in the Universal Declaration of Human Rights.

Our common future will depend on the degree to which we all become better world citizens, creating the unity within diversity which stems from an intercultural education which helps us to

build strong cultural roots, to understand and respect the cultures of others and to learn to live together harmoniously in multicultural communities.

### REFERENCES

- Bray, M. (1999) *The shadow education system: private tutoring and its implications for planning*. UNESCO-IIEP.
- DFID (1999) *Economic Well-being*. Consultation Document DFID.
- Gargliardi, R. (1995) *Teacher Training and Multiculturalism*. Geneva: IBE-UNESCO.
- Inglis, C. (1996) *Multiculturalism: New Policy Responses to Diversity*. Paris: UNESCO.
- Mortimore, P. and Whitty, G. (1997) *Can school improvements overcome the effects of disadvantage*. Institute of Education, University of London.
- ODA (2000) The Reality of Aid 1999 (cited by *The Economist*, January 8, 2000)
- O'Rourke, K. and Williamson, J. (1999) *Globalisation and History: The Evolution of Nineteenth Century Atlantic Economy*. MIT.
- Power, C. (1998) Initial training of teachers and Professors. In *Aprender para el Futurro*. Madrid: Santillana Foundation.
- Power, C. (1999) *Concepts of a Better World in a Cross-Cultural Perspective*. 40<sup>th</sup> WEF International Conference.
- Power, C. (2000) Learning to live together. *Education International*, January 2000.
- Teasdale R. (1992) *Voices in a Seashell: Education, Culture and Identity*. Institute of Pacific Studies & UNESCO.
- UNDP (1999) *World Development Report*. NY: UNDP.
- UNESCO (1996) *Learning: the Treasure Within*. Report to UNESCO of the International Commission on Education for the 21<sup>st</sup> Century.(Chair: J.Delors) Paris: UNESCO.
- UNESCO (2000) *World Education Report*. Paris: UNESCO.
- Widden, M., Mayer-Smith, J. and Moon, B. (1998) Critical analysis of the research on learning to teach. *Review of Research on Education*, 68(2), 130-178.

## Errors: What are they and how significant are they?

---

**John P. Keeves**  
**Trevor G. Johnson**  
**Tilahun M. Afrassa**

Flinders University of South Australia *john.keeves@flinders.edu.au*

### THE NATURE OF ERRORS

Errors in educational research and measurement arise from four main sources:

- (a) errors associated with the characteristic being measured – intrinsic errors,
- (b) errors arising from the instrument being used – instrumental errors,
- (c) errors involved in the act of measurement – observational errors.

In addition, since it is rarely possible to take measurements of a complete population there are

- (d) errors arising from the process of sampling – sampling errors.

Sampling errors are of two types. First, there are errors arising from a sample not being fully representative of the population from which it is drawn-sample bias. Secondly, there are errors that arise from the variability among the cases included in the sample, which can be estimated from information on the variability between cases and the number of cases-standard errors of sampling. Estimates of the standard error of sampling permit inferences to be drawn about the range of a characteristic in the population.

The word “error” has many meanings. The most common meaning is concerned with the idea of a “mistake” which does not apply in this context. A further meaning is concerned with “the difference between an observed or estimated numerical result and the true or exact one”. However, in educational research the “true value” is both unknown and unknowable and this meaning does not apply. In statistical work the term “error” simply means “the action of wandering”, since the observed values are dispersed about a central value and are assumed to be as likely to be greater than this central value as they are to be less than the central value. This “errant” or “wandering” nature of observations applies to all four types of error considered above. However, it does not apply to sample bias. In order to make some allowance for sample bias, prior knowledge is needed. The making of statistical estimates that are based on prior knowledge lies in the domain of Bayesian statistics. Bayesian procedures were employed in statistical estimation in the Australian Studies of School Performance in 1976 and 1981 (Morgan, 1978), but have not been used since in other Australian studies of student achievement.

The examination of error in educational research, when Bayesian procedures are not employed, is built around the idea of the **importance** of findings; namely, **pattern of results, size of effect** and **statistical significance**. This paper is concerned with the **examination of errors** in several recent Australian research studies.

## IMPORTANCE AND SIGNIFICANCE

Increased access to computers for the processing of data collected in large surveys of educational outcomes has recently raised issues concerned with assessing the importance or significance of findings in educational research. In Australia, although the Curriculum Survey (Radford, 1951) was conducted by ACER in 1947, it was not until the First IEA Mathematics Study (FIMS) was carried out in 1964, that the value of regular surveys of student achievement and attitudes was recognized. Today, not only do the IEA studies continue, but the PISA project conducted by OECD, the Basic Skills Testing Programs which are held annually in each state, and the Course Experience Questionnaire, administered to graduating university students, are in operation, while university entrance and completion tests are under development. In some studies efforts are made to draw large random samples, while in other studies attempts are made to capture all members of a target population. The speed and accuracy with which computers and electronic equipment can now scan documents and process data remove some constraints on the size of the student groups under survey.

The issues that have arisen are largely in the interpretation of the findings and their importance or significance. However, there are the related problems of the unknown bias that arises from a less than adequate level of response both in the proportion of respondents and in the meaningfulness of their responses to the survey instruments, due not only to omission, but also to lack of motivation to respond.

The strength and value of the surveys undertaken across educational systems in Australia today, whether they involve a sample or a census of a defined target population, lies in the opportunity to monitor change over time as well as to provide estimates for comparisons between like groups through replication. Since education is primarily concerned with learning and development, it is the monitoring of change over time that is emerging as the aspect of greater interest. The estimation of level of performance and the attainment of benchmarks or standards are also of some interest, but interpretation of findings suffers from the judgmental nature of the tasks of standard setting and the specification of desired levels of performance. The monitoring of change over time involves not only the system, but also the school and classroom, and above all else the learning achieved by each individual student and the development taking place in each individual child.

It is in the examination of learning and development, that the monitoring of change over time has the potential to make its greatest contribution to education. This paper has a main purpose of addressing certain issues that have arisen in educational research as a consequence of this increased emphasis on the use of large scale surveys of educational outcomes to monitor change over time. These problems involve, in the main, the procedures employed to assess the importance of the findings from surveys and censuses. Unfortunately, the standard texts on educational research methodology are written as course books for undergraduate and postgraduate students in education, psychology and sociology. These texts do not consider large scale surveys, but only small studies that are undertaken in a single school or institution. Consequently, some of the issues that arise are not raised in courses at universities.

Unfortunately too, there is marked controversy between statisticians with respect to the three major approaches to significance testing, namely:

1. the Fisherian test of the null hypothesis;
2. the Neyman-Pearson test for the choice between two alternative hypotheses leading to the making of decisions for policy and practice; and

3. Bayesian tests that take into account prior information before making a decision.

The approach that is increasingly being used in educational research for estimation and significance testing is based on Fisher's ideas of likelihood. Under this approach three things must be available:

1. the hypothesis or model that specifies how the observed data were generated;
2. the nature of the distribution under which the data were generated; and
3. data that have been collected and that can be used in testing the hypothesis or model.

The question is whether the model or hypothesis is adequate to explain the generation of the observed data, or whether the model or hypothesis must be rejected. The probabilities that are employed in testing are not about the parameters of the model. They are concerned with the data and whether the data could have been generated by the model or the hypothesis. The model can never be said to be true, but it can be provisionally accepted as adequate. The true value of any parameter that is being estimated is unknowable. The question is whether the model fits the data, and if so, the task is to estimate the parameters of the model. The computer programs used today in educational research employ this likelihood approach whether they are concerned with multivariate or multilevel analysis, or with the scaling of data collected with achievement tests or attitude scales.

### **SCALING OF DATA**

The scaling of data in most Australian studies employs the Rasch or one-parameter logistic model. The model, based on the conjoint measurement of student performance and item difficulty, employs the logistic transformation and a probabilistic approach. In contrast to the two-parameter and three-parameter models, it provides measures of student performance on a scale that is independent of both the items employed and the persons who responded. Moreover, the scale has a natural metric provided as the unit of measurement - the logit. The only property of the scale that is arbitrary is the fixed point or origin. Thus the scale of measurement has the properties of an interval scale, but not of a ratio scale. The major advantages of the use of the Rasch model, provided that the model fits the data and the requirement of unidimensionality is satisfied, are:

1. the errors involved in measurement of items and persons can be estimated;
2. data sets can be readily equated;
3. differential item functioning for different subgroups of persons can be readily detected; and
4. the use of an interval scale provides measures of change on a consistent metric across the full range of the scale.

### **SAMPLE SURVEYS AND CENSUSES**

It is essential to recognize that whether a sample survey or a census is conducted in educational research the units in operation are the student, the classroom, the school or institution and the system. As a consequence students are clustered within classrooms, classrooms are clustered within schools and schools are clustered within systems. Treatments are administered at all four levels of the system, the school, the classroom and the student. The analysis of data in educational research must recognize this nested or clustered nature of the data, whether the study is a sample survey or a census.

If a sample survey is undertaken there is a further complexity in so far as the school is commonly the primary sampling unit, and either intact classrooms or students are sampled from within the

school at a second stage. Random selection occurs at both stages, largely to ensure representativeness for subsequent generalization. Moreover, if random selection has occurred in sampling, it is also possible to make statements about the size of the errors of sampling. Nevertheless, it is rare in educational research to employ a simple random sample, as a consequence most samples employed are complex or clustered samples. Furthermore, it is rare for treatments to be applied solely at the level of the individual student and the complex structure of the data, for both surveys and censuses, must be taken into consideration in the analysis of the data. Since, estimates of error are used in significance testing, failure to consider the complex structure of both the sample and the data gives rise to gross mistakes in much testing for statistical significance. It is necessary to recognize that the estimates of sampling error are commonly faulty because students are nested within classroom groups, and classroom groups are nested within schools and schools are nested within systems. Consequently the simple random sample estimates of error provided by computer programs, with the exceptions of WesVarPC (1997) and multilevel analysis programs such as HLM (Bryk, Raudenbush and Congden, 1996) and MLwiN (Rasbush, Healy, Browne, & Cameron, 1998), are the sources of these gross mistakes.

In the main, significance testing is primarily conducted to identify findings that are considered of importance. In general, it is assumed that if an effect involves statistical significance at the five per cent level, it is of some importance, and if the finding involves statistical significance at the one per cent level it is of greater importance. However, the level of statistical significance is dependent on sample size. Nevertheless, sample size is not the only characteristic to be considered. It is also necessary to take into account the structure of the sample or the census data and sometimes to consider the proportion of the target population tested when the finite population correction is used.

The consequences of the structure of the data must be discussed in addressing issues of importance in the examination of the findings of sample surveys and censuses. It is here that text and reference works on educational research and measurement are seriously at fault.

### SOURCES OF DATA

In the illustration of some of the consequences of failure to address in appropriate ways some of the issues that arise in the examination of findings in educational research, data have been drawn from several sources. First, there are analyses of data collected with the Course Experience Questionnaire from graduating students. Secondly, there are analyses of data collected in the Basic Skills Testing Program in South Australia in 1995 and 1999. Thirdly, there are data collected in the First, Second and Third IEA Mathematics Studies in Australia in 1964, 1978 and 1994 respectively. Work has been done on the analyses of these data sets by staff and postgraduate students at Flinders University. We are grateful to have access to these analyses to provide illustrations of effects that are of interest. These effects arise in attempts to assess the importance of findings. This discussion is presented not to draw attention to gross mistakes, but to stimulate discussion of the issues that have arisen in educational research and measurement in Australia.

### ISSUES OF SIGNIFICANCE

Statisticians have promoted a concern for **statistical significance** as the over-riding indicator of the importance of findings. They have largely ignored consideration of the **size of an effect**, except in power calculations, and the estimation of appropriate sample size, and have underemphasized the usefulness of the **pattern of results**, which is involved both in replication and in the monitoring of change over time. All three aspects of the importance of findings, namely, statistical significance, size of effect, and pattern of results must be considered.

## **PATTERN OF RESULTS**

Interest in the pattern of results employs two approaches. First, there is the replication of effects in comparison with other similar groups under survey. Thus there is interest in the Basic Skills Testing Program for comparisons between performances within a groups of like schools. Alternatively, there is interest in comparisons within a school of the performance of similar classroom groups, since the classroom is the unit of instruction. There is also interest in comparisons between schools systems, as exist in each of the Australian states, or between countries as occurs in the IEA or PISA Projects. Secondly, there is interest in the changes that occur over time or the monitoring of performance at the student, school or system levels.

In its simplest form the pattern of results can be assessed by simple comparisons of greater than, equal to, or less than and the counting of pluses and minuses. However, such comparisons lend themselves to statistical analysis or meta analysis, that can now be readily carried out using multilevel analysis procedures. Likewise, the examination of change over time, provided three or more measures of an outcome are available for between time comparisons, can also be readily undertaken using multilevel analysis, if change is modelled as a simple linear or quadratic function of time. Alternatively, if a large enough number of time points is available, event history analysis can be employed. These procedures of analysis are, however, dependent on both issues concerned with the size of an effect that is considered to be of importance and with the statistical significance tests that are applied at many stages in the calculations. Thus the pattern of results of itself is not the sole test to be employed in the assessment of the importance of findings. It is here that the Bayesian approach to statistical theory is likely to come into greater prominence in the years ahead.

### **Some Illustrations of Pattern of Results**

#### ***Examination of change over time***

As a first example in the examination of change over time, data collected in the First, Second and Third IEA Mathematics Studies in 1964, 1978 and 1994 respectively are employed to illustrate trends over time (Afrassa and Keeves, 1997). The FIMS and SIMS data provided estimates of mathematics achievement for 13-year-old students for government schools for five of the eight school systems, while the FIMS and TIMS data provided estimates of mathematics achievement for Year 8 students in the same five government school systems. Performance in mathematics is recorded on a Rasch scale, using a metric of centilogits, and with the fixed point set at 500, which was the difficulty level of the 1964 FIMS mathematics tests (A, B and C). Figure 1 records the estimates of the group means and their standard errors in parentheses. The pattern of the findings is clear and consistent across occasions. However, the issue arises as to whether the declines in performance over time are of consequence or importance. Moreover, since five state school systems were involved it is of interest to consider whether the same pattern is observed for Australia overall as is detected for each of the five systems. Figure 2 presents the findings for each school system for the comparisons between FIMS (1964) and SIMS (1978). While Figure 3 presents the findings for the comparisons between FIMS (1964) and TIMS (1994). The larger standard errors for TIMS compared with FIMS and SIMS should be noted in spite of the greatly increased sample sizes. The issue that must be addressed is whether these effects are of importance both in magnitude and with respect to statistical significance. It is also of interest to consider whether the large standard errors for TIMS greatly reduce the probability of detecting a significant difference. It should be noted that in TIMS intact classes were sampled at the second stage after schools were sampled at the first stage while in FIMS and SIMS, students within schools were sampled at the second stage. This difference in sample design in TIMS gives rise to

rather larger design effects. It should be noted that one school system recorded an apparent rise in mathematics achievement over the 30 year period while one school system recorded no change, and the other three systems provided evidence of apparent declines.

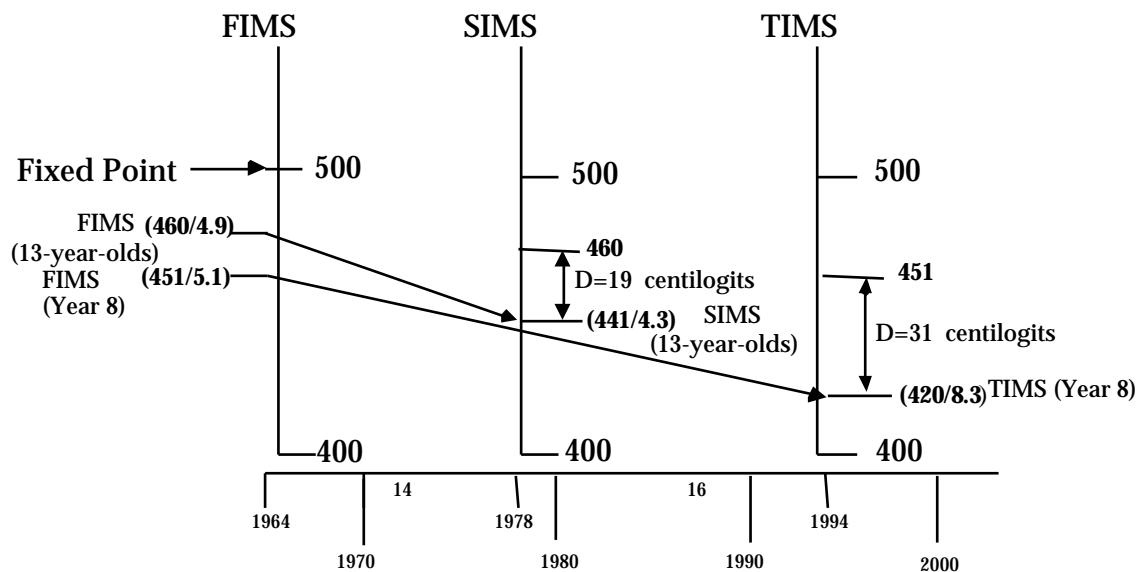

Fixed point = Mean difficulty level of FIMS test; 100 units = 1 logit; 1 unit = 1 centilogit  
 D = difference in mathematics achievement between occasions  
 Values in parentheses are Rasch estimated mean scores and standard errors of the means respectively  
 $D_{1978-1964} = 19$  centilogits or half year of mathematics learning  
 $D_{1994-1964} = 31$  centilogits or 0.8 year of mathematics learning  
 One year of mathematics learning is estimated to be 37 centilogits.

**Figure 1. Comparison of Achievement in Mathematics between 1964, 1978 and 1994 in Australia**

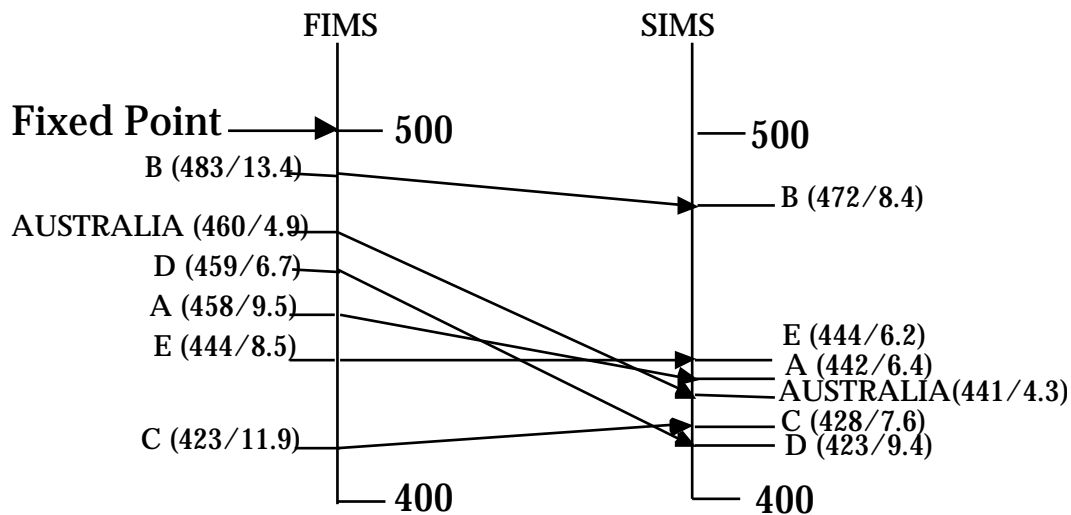

Fixed point = Mean difficulty level of FIMS test; 100 units = 1 logit; 1 unit = 1 centilogit  
 Values in brackets are Rasch estimated mean scores and standard errors of the mean respectively  
 A = State A, B = State B, C = State C, D = State D, E = State E.  
 One year of mathematics learning is estimated to be 37 centilogits.

**Figure 2. Comparison of Achievement in Mathematics between 1964 and 1978 in Australia for 13-year-old students**

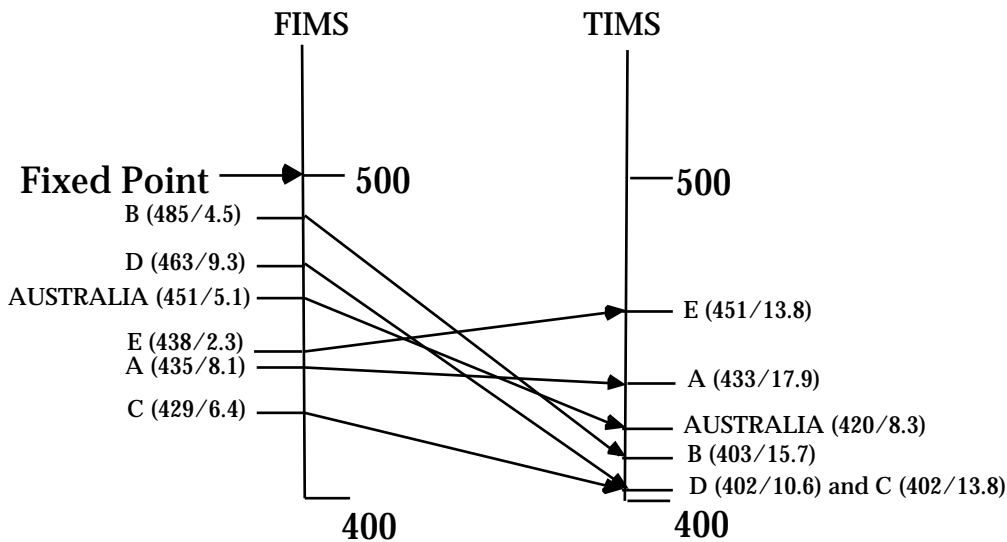

Fixed point = Mean difficulty level of FIMS test; 100 units = 1 logit; 1 unit = 1 centilogit

Values in parentheses are Rasch estimated mean scores and standard errors of the mean respectively

A = State A, B = State B, C = State C, D = State D, E = State E.

One year of mathematics learning is estimated to be 37 centilogits.

**Figure 3. Comparison of Achievement in Mathematics between 1964 and 1994 in Australia for Grade 8 students**

### Size of Effects

The apparent declines recorded in Figure 1 raise the question as to whether changes in mathematics achievement of 0.19 and 0.31 logits are of sufficient magnitude to be of practical significance.

There are three ways in which the size of an effect is estimated.

#### *Standardized mean difference*

Many studies have estimated correlations between a criterion measure and the performance of two groups and the correlation coefficient is used to summarize the findings of the study, since larger correlations indicate stronger relationships. Thus a correlation coefficient can be readily converted to a standardized mean difference in which the difference between the two group means is divided by the common standard deviation and the mean difference is expressed in standard deviation units. This standardized mean difference is generally known as an **effect size**. Cohen (1988) has provided three rules of thumb for assessing the magnitude of an effect size:

Small: 0.20 standard deviations, or a correlation of 0.10, or the difference between 50 and 45 per cent;

Medium: 0.50 standard deviations, or a correlation of 0.30, or the difference between 50 and 35 per cent;

Large: 0.80 standard deviations, or a correlation of 0.50, or the difference between 50 and 25 per cent.

Table 1 records the estimated effect sizes for differences in mathematics achievement for FIMS, SIMS and TIMS that are shown in Figures 1, 2 and 3.

**Table 1. Effect Size Difference in Mathematics Achievement for FIMS (1964), SIMS (1978) and TIMS (1994)**

State	D <sub>1978-1964</sub> 13-year-old-students	D <sub>1994-1964</sub> Grade 8 students
State A	-0.16	-0.02
State B	-0.11	-0.83 (L)
State C	0.05	-0.28 (S)
State D	-0.36 (S)	-0.59 (M)
State E	0.00	0.14
Australia	-0.19	-0.29 (S)

Recorded in parenthesis are the assessed magnitudes of effect sizes  
S – Small; M – medium; L – Large

All scores are recorded on the TIMS standardized scales for mathematics

### *Standardized scale difference*

The tradition at the Educational Testing Service in the United States has been to construct a standardized scale of achievement in which either 50 units (for National Assessment of Educational Progress) or 100 units (for SAT scores) correspond, at least initially when the scale was first calibrated, to a pooled student standard deviation for a somewhat arbitrary sample of students. Table 2 records the mean scores in mathematics achievement for the eight Australian school systems for Year 8 level, Level 1, Level 2 and the difference between Level 1 and Level 2 which indicates the gain in scores between adjacent grades obtained for the TIMS study in Australia using standardized scale differences on a 100 unit scale (Lokan, Ford and Greenwood, 1996), that is similar to the scales constructed by the educational testing service.

**Table 2. Estimated gains in mathematics achievement across adjacent grades in TIMS study using standardized scale values**

Mean mathematics achievement score measured in centilogits	Age In years	Year 8	Adjacent year Levels		Gain Level 2-Level 1
			Level 1 <sup>a</sup>	Level 2 <sup>b</sup>	
New South Wales	14.1	522 ± 9	495 ± 9	522 ± 9	27
Victoria	14.0	511 ± 7	475 ± 8	511 ± 7	36
Queensland	13.5	512 ± 8	512 ± 8	547 ± 8	35
Western Australia	13.5	532 ± 8	532 ± 8	561 ± 11	29
South Australia	13.8	516 ± 6	516 ± 6	557 ± 6	41
Tasmania	14.0	501 ± 12	473 ± 12	501 ± 12	28
Australian Capital Territory	14.1	548 ± 12	540 ± 14	548 ± 12	8
Northern Territory	13.8	478 ± 20	478 ± 20	494 ± 14	16
Australia	-	-	498 ± 3.8	530 ± 4.0	32

All scores are recorded on the TIMS standardized scales for mathematics

a Year 7 in NSW, Vic, Tas and ACT, and Year 8 in Qld, WA, SA and NT

b Year 8 in NSW, Vic, Tas and ACT and Year 9 in Qld, WA, SA, and NT

Scale units in centilogits; Standard errors of mean values are recorded alongside estimated mean values

The gain in mathematics achievement for a year of schooling across Australia is estimated to be 0.32 units on a rather arbitrary international scale (Lokan, et al. 1996). It should be noted that it is only meaningful to compare performances between states at the Year 8 level, and even here the differences in ages between the Year 8 groups in the different states should be noted. However, it would also be possible to report an age-adjusted score, since the growth during a year of schooling across Australia has been estimated. It is clearly not meaningful to make comparisons between states within Level 1 or Level 2, because of the very different periods of schooling involved.

**Logit scale differences**

The natural unit of the logistic scale employed in Rasch measurement procedures is the logit, and it is now common in the construction of Rasch scaled scores to employ a scale mean of 500 and to use the centilogit as the scale metric (Keeves and Schleicher, 1992). Work on the 1995 Basic Skills Test data in South Australia to examine change in scaled scores between Year 3 and 5 in both Literacy and Numeracy yielded a surprisingly simple relationship that the growth over a two year period was almost exactly 1.00 logits or 100 centilogits. It is estimated that the growth across Year 3 and Year 5 in both Literacy and Numeracy is 50 centilogits. Keeves and Schleicher (1992) have estimated that the growth in Australia from Age 10 to Age 14 in Science is 135 centilogits and the growth per year in this age span can be estimated as 34 centilogits. Schleicher (1994) has estimated in several different ways that the approximate growth in reading achievement from Age 9 to Age 13 is 21 centilogits. Moreover, Afrassa (1998) has estimated that the growth in mathematics achievement between one grade level and the next in Australia in the TIMS study is 37 centilogits, which is consistent with the estimate recorded in Table 1 on the TIMS scale, since the standard deviation employed was estimated to be approximately 120 logits. Table 3 summarizes in scale units the learning in one year obtained from different studies.

**Table 3. Growth for learning in one year expressed in centilogits**

Field	Year	Grade	Country	Growth/year
Basic Skills				
Literacy	1995	Year 3 to 5	South Australia	0.50
Numeracy	1995	Year 3 to 5	South Australia	0.50
Science	1984	Ages 10 to 14	Australia	0.34
Mathematics	1994	Grades 7 to 8	Australia	0.37
Reading Literacy	1990	Ages 9 to 13	All countries	0.21

It is evident that using the Rasch scale it is possible to interpret the differences recorded in Figure 1 for the decline (19 units) in mathematics achievement across Australian between FIMS (1964) and SIMS (1978) in terms of half a year (19/37 units) of student learning, and the decline (31 units) in mathematics achievement across Australia between FIMS (1964) and TIMS (1994) as approximately four-fifths (31/37) of a year of learning of mathematics. It should be noted that in one school system between 1964 and 1994 the gain (13 units) is estimated to be approximately one third (13/37 units) of a year of mathematics learning. The interpretation of change in achievement in terms of years and/or months of school learning would seem to add meaning to the estimates made when the Rasch scale is employed. Nevertheless, it is also of some concern to estimate in terms of years of school learning the magnitudes of the standard errors that are recorded in Table 2 for system mean values for the TIMS study. Moreover, the estimated magnitudes of growth recorded in Table 2 for the eight school systems are so different as to suggest serious bias in some of the mean values recorded in this table.

**STATISTICAL SIGNIFICANCE**

The initial problem to be considered in the examination of data collected in the Basic Skills Testing Program and through the Course Experience Questionnaire, where an attempt is made to provide a study in which all members of the target population are involved, is whether a sample survey or a census has been undertaken. Inevitably, there are losses at both the institution and student within institution levels. An initial question must be asked is whether the losses introduce bias, and how the extent of bias could be assessed. Further questions must be addressed.

1. If a sample survey is considered to be a meaningful description, with the initial target population being the year group population to which generalization is made, should a finite population correction be made to the estimates of error?
2. If a sample survey is considered to be a meaningful description, is the target population the successive year groups from which one year group forms the sample, and is a finite population correction inappropriate?
3. If a census is considered to be a meaningful description can a standard error of the mean value be meaningfully calculated for the census data?
4. In the calculation of the standard error of a mean value, how is the complex structure of the data collected taken into consideration, since it involves institutions, classrooms, and students at successive levels of analysis? This latter question must apply irrespective of whether a sample survey or a census is considered to be a meaningful description, and if an estimate of the standard error of a mean value is to be calculated.
5. How should the standard errors for comparisons between schools within one system and within one year group be calculated?
6. How should the standard errors for comparisons for one school across several years be calculated?

It is clear that many computer packages completely ignore the problems raised, as do most standard text and reference books. Yet the problems remain, because it would seem desirable to make some estimate of the error associated with a mean value, even if statistical significance testing were abandoned.

Successive attempts to calculate standard errors of the mean values for complex samples have involved:

- (a) the use of four subsamples (see Husen, 1967; Keeves, 1966);
- (b) the use of jackknifing with ten subsamples (see Peaker, 1975; Ross, 1978);
- (c) the use of jackknifing deleting one primary sampling unit at a time (see Rust, 1985; Ross, 1991)

Westat in the United States has released a computer package WesVar PC (Brick, et al., 1997) that builds on the jackknifing procedure advanced by Rust (1985) in order to compare mean values, and percentages, as well as to calculate sampling errors in regression analysis for complex sample designs. The WesVar PC program considers each institution as a primary sampling unit with students selected from within each primary sampling unit at a second stage. It employs a procedure involving the dropping of one primary sampling unit at a time and then estimates the parameter for the truncated sample. This step is repeated (n-1) times, where n is the number of primary sampling units, and the (n-1) estimates of the parameter are used to calculate both the jackknife mean and a jackknife standard deviation of that mean. The deviation of the jackknife mean from the full sample estimate of the mean is considered to be an index of bias, and the jackknife standard deviation is considered to be an estimate of the standard error of the mean (see Ross and Rust, 1997).

This approach regards the sample as a subpopulation and jackknifing involves successive samples drawn from that subpopulation to provide an estimate of the error involved in calculating the mean of the subpopulation. The treatment of the estimation of error in this way would seem to avoid

many of the problems that are involved in the use of both formula estimates of standard errors and the logical problems associated with the relationships between the sample and the target population. However, all that is produced is an estimate of a parameter and an estimate of the standard error of that parameter from which a confidence interval can be specified. The WesVar PC program provides for the statistical comparison of subgroups with appropriate significance tests. Comparisons between separate subgroups must be carried out through further analyses.

Table 4 presents a comparison between WesVar PC estimates of error and the SPSS estimates of error for the six Course Experience Questionnaire scales. The table records estimates of the design effect (deff) which is an indicator of the effect of the complex sample design on the estimation of error for the mean value of each scale.

**Table 4. The Influence of the Structure of the Data on Standard Errors of the CEQ Scale Mean (fpc=1)**

CEQ Scale/Index	SPSS		WesVar PC					
	Mean	SE <sub>SRS</sub>	Mean	SE <sub>C</sub>	N	Deff	Deft	SE <sub>C</sub> /SE <sub>SRS</sub>
Good Teaching	11.12	0.165	11.12	0.988	6,0009	33.72	5.98	5.98
Clear Goals & Standards	19.51	0.157	19.51	0.652	6,0009	17.18	4.14	4.14
Appropriate Workload	3.49	0.155	3.49	0.796	6,0009	26.29	5.13	5.13
Appropriate Assessment	28.75	0.177	28.75	0.888	6,0009	25.16	5.02	5.02
General Skills	33.72	0.137	33.72	0.559	6,0009	16.59	4.07	4.07
Overall Satisfaction Index	36.65	0.198	36.65	0.995	6,0009	25.38	5.04	5.04

fpc = finite population correction

SE<sub>SRS</sub> = standard error of a simple random sample

SE<sub>C</sub> = standard error of a complex sample

Deff = design effect

Deft = deff

The design effect (deff) is given by

$$\text{deff} = \frac{\text{Variance of complex sample estimate}}{\text{Variance of simple random sample of same size}} = \frac{V_c}{V_{\text{srs}}}$$

The value of deff or deff is the factor by which sampling errors calculated using simple random sample formulae must be multiplied in order to obtain estimates that reflect the clustering effects of students within institutions. The far right hand column in Table 4 shows that deff as the square root of deff is the same as the standard error for the complex sample divided by the standard error of the simple random sample of the same size, given in columns 4 and 2 of Table 4 respectively, when the finite population correction is not used. When the finite population correction is used, deff is somewhat smaller than  $V_c/V_{\text{srs}}$ .

### **Multilevel analysis programs**

Several multilevel analyses programs are now available that take into account the nesting of students within institutions and, as a consequence, generate more appropriate estimates of standard errors than do traditional computing programs. These multilevel analysis programs include:

- (a) HLM 4.01 (Bryk, Raudenbush and Congdon, 1996)
- (b) MlwiN (Rasbash, Healy, Browne, and Cameron, 1998).

It should be noted that HLM is relatively easy to use and the program reads data from a number of sources such as SPSS and SAS. WesVar PC is specially designed for the analysis of data in survey research and not for multilevel analysis.

The data for the six scales of the Course Experience Questionnaire (CEQ) were analysed using both MLwiN and HLM4.01 to demonstrate that the estimates were comparable. In addition, it was possible to compare the estimates of the mean values and their standard errors for these two multilevel programs with those obtained by WesVar PC. Table 5 compares the estimates for MLwiN1.02 and HLM4.01 for the fully unconditional model that is equivalent to a one-way ANOVA in the analysis of the CEQ data.

**Table 5. Comparisons for Means and Standard Errors of CEQ scores between MLwiN and HLM**

Scale/Index	MLwiN1.02 Estimates			HLM4.01 Estimates		
	Estimate	SE	(rho)	Estimate	SE	(rho)
Good Teaching	12.77	1.02	0.02	12.77	1.03	0.02
Clear Goals & Standards	20.09	0.61	0.01	20.09	0.62	0.01
Appropriate Workload	4.24	0.76	0.01	4.24	0.77	0.01
Appropriate Assessment	29.49	0.95	0.02	29.49	0.96	0.02
General Skills	34.27	0.51	0.01	34.27	0.52	0.01
Overall Satisfaction Index	38.01	0.89	0.01	38.02	0.90	0.01

(rho) is the intraclass correlation coefficient

The grand means for the scales differ noticeably for MLwiN and HLM from those obtained from SPSS and WesVar PC. One reason for this is that the single level and multilevel estimates are for slightly different data sets. Cases containing missing data at Level 2 (the institutional level) can not be included in the multilevel analyses. It should also be noted that the multilevel estimates of the standard errors of the mean values recorded in Table 5 are of similar magnitude to the WesVar PC estimates recorded in Table 4. Consequently, these findings further reinforce the view that traditional methods recorded from SPSS in Table 4 seriously underestimate the standard errors of clustered or nested data. It follows that the confidence intervals calculated by traditional procedures are likely to be too narrow and erroneous conclusions are likely to be recorded for the statistical significance of observed differences. In addition, it should be noted that these differences arise even where the intraclass correlation coefficient which is also an index of the clustered nature of the sample is seemingly small.

The intraclass correlation coefficient is defined as:

$$= \frac{\sigma_g^2}{\sigma_g^2 + \sigma_w^2}$$

Where  $\sigma_g^2$  = variance associated with groups,  
 $\sigma_w^2$  = error variance within groups,  
 $\sigma_g^2 + \sigma_w^2$  = total variance.

In making comparisons between institutions these substantial differences between the standard errors calculated for a sample of complex design must be taken into consideration. Over 40 years ago Kish (1957) discussed the consequences of applying the usual standard error formulae found in text books to data obtained from complex samples and concluded that:

In the social sciences the use of SRS (simple random sample) formulas on data from complex samples is now the most frequent source of gross mistakes in the construction of confidence statements and tests of hypotheses. (Kish, 1957, p. 157)

Nevertheless, 40 years later these gross mistakes are still wide spread. The same problem arises within schools where classrooms are the units of instruction and all members of the school are

tested. The students can not be considered to be independent of one another and there is commonly marked clustering of students within class groups. The calculation of the standard errors of estimate for the mean value of a school must be obtained either by WesVar PC or by multilevel analysis with students nested within classrooms. Failure to recognize this problem in data analysis must lead to seriously erroneous conclusions about performance at the school level. Where students are randomly assigned to classes at the beginning of a school year the clustering effects might be thought to be small. However, teachers do have an effect during a school year and thus treatment conditions vary and must be taken into consideration in the estimation of errors. The effects of streaming or setting into class groups significantly accentuate this problem.

This discussion of issues of importance and statistical significance provides the necessary basis for consideration of errors of measurement and their effects on the estimation of student performance in such studies as the Basic Skills Tests and the TIMS and PISA testing programs.

### **ERRORS OF MEASUREMENT**

For 20 years the ACER has gradually advanced the use of Rasch measurement in school systems across Australia, in spite of marked opposition led by academics from the University of London and some statisticians in the United States. The major advantages of the use of Rasch measurement procedures are, first, that provided a test can be considered to be unidimensional, and the items contained within a test satisfy the requirement of unidimensionality, then estimates of performance on that scale are independent of the items employed. Furthermore, the estimates of performance are also independent of the persons employed in the calibration of the scale. As a consequence of these properties it is readily possible for tests employed at different grade levels and on different occasions to be equated on a single common scale.

Secondly, it is possible to make estimates of the errors of measurement for both different items and different persons and different points on the scale of measurement.

### **ERRORS IN RASCH SCALED SCORES**

Table 6 records the errors of measurement for persons on the 1999 Basic Skills Tests of Literacy and Numeracy at selected score levels on the scales of measurement developed which are expressed in logits.

The score values and their standard errors show different standard errors at different levels of the scale. However, the standard errors can be interpreted in terms of a year of learning that is estimated to be 0.50 logits. Thus the smallest standard error of a Rasch scaled score in the Basic Skills Tests recorded for Year 5 Literacy is estimated to be as large as half a year of learning, while the largest standard errors are equivalent to two years of learning. These estimates were made using the QUEST computer program (Adams and Khoo, 1993).

The standard deviation of the Rasch scaled scores is found to be approximately one logit. This indicates that all standard errors have at least a small effect size lying in the range from 0.20 to 0.50, and the standard errors in the outer categories have a medium effect size being greater than 0.50 and less than 0.80, while the extreme scores have standard errors of effect size in the large category being greater than 0.80. The magnitudes of these standard errors are surely unacceptably large, when assessed in this way.

It must be asked whether the use of CONQUEST (Adams, Wilson and Wu, 1998) would yield noticeably smaller standard errors, perhaps down to the size of 0.10 logits. It must also be asked

whether the procedures employed for calculating standard errors are really appropriate. Further questions readily come to mind.

1. Do the procedures for estimating standard errors take into consideration the fact that individual items are nested within blocks with a common stem?
2. What are the consequences of relatively large standard errors in the estimated scores on the Basic Skills Tests for the classification of the performance of students in skill bands?
3. Is performance on the subscales of Number, Measurement and Space of sufficient accuracy to be meaningful, without the use of Bayesian procedures?
4. How does the estimated accuracy of the raw scores compare with the estimated accuracy of the Rasch scaled scores?
5. Should the Basic Skills Tests be focussed at the ability level of the student with the same number of items, but differing for each student so that the items are spread over a narrow band. With more focussed items, a more accurate estimation of student performance could be made. Computer adaptive testing might provide this gain in accuracy?

**Table 6. Score values and their standard errors in Basic Skills Tests in 1999 in South Australia.**

	Literacy			Numeracy		
	Raw Score <sup>a b c</sup>	Scaled score	Std error	Raw Score	Scaled score	Std error
<b>Year 3</b>						
Top of Scale	62	4.77	1.03	34	3.89	1.06
Band 5	57	2.73	0.46	32	2.58	0.66
Band 4	48	1.42	0.33	28	1.35	0.49
Band 3	39	0.57	0.29	23	0.34	0.42
Band 2	29	-0.27	0.29	18	-0.52	0.41
Band 1	13	-1.78	0.35	10	-1.90	0.44
Band 0	2	-4.14	0.74	2	-4.20	0.77
Bottom of scale	1	-4.88	1.02	1	-5.00	1.04
<b>Year 5</b>						
Top of Scale	83	6.06	1.04	47	4.94	1.03
Band 6	77	3.74	0.44	44	3.37	0.56
Band 5	65	2.22	0.30	38	2.10	0.40
Band 4	55	1.40	0.27	31	1.16	0.35
Band 3	42	0.50	0.26	24	0.35	0.34
Band 2	30	-0.34	0.27	17	-0.47	0.35
Band 1	13	-1.84	0.34	8	-1.80	0.44
Band 0	2	-4.18	0.74	2	-3.63	0.76
Bottom of scale	1	-4.92	1.02	1	-4.40	1.04

a - Perfect scores and zero scores omitted

b - Scores recorded for midpoint of band

c - Scaled scores and standard errors expressed in logits

It should be acknowledged that these measurement procedures using Rasch scaling were originally developed for large scale survey testing programs, where the errors of measurement were small because of the large sample sizes, and the sampling errors were of greater concern. However, today these measurement procedures are being used for the estimation of individual student performance, where the errors of measurement are large and the sampling errors are irrelevant.

### EQUATING ERRORS

The tests administered each year are converted to measures on a standard scale that was constructed several years earlier. Each year the test for that year is equated with tests employed during earlier years and with the scale developed from those tests. Consideration needs to be given to the estimation of the equating errors introduced. The magnitude of the equating errors will depend on the equating procedure employed, whether it involves concurrent equating, or anchor item equating, or common item difference equating, and the sizes of the errors associated with the calibration of the separate tests being equated. It would seem that the magnitude of the errors of equating should involve both the numbers of common items and the numbers of common persons involved in the test equating operation, as well as the complexity of structure of both the data concerned with the items and persons.

### CALIBRATION ERRORS

The test of fit to the data recorded for a particular item in order to assess whether the item satisfies the requirement of unidimensionality is a relative test and not an absolute one. Moreover, a balance must be achieved between the **bandwidth** of a range of items, each assessing slightly different aspects of the characteristics under examination and the **fidelity** of the items with respect to the unidimensional scale (see Cronbach, 1960). As a consequence, it is sometimes necessary to eliminate from a test those items that have apparently high fidelity but assess over too narrow a bandwidth, and thus supply redundant information, as well as items that have too low fidelity and are spread over too wide a bandwidth. Different computer programs for Rasch scaling use different indices for the testing of item fit, that give very different results for items of marginal fit. Moreover, the effects of sample structure on indices of item fit need to be further investigated, since only one study has been carried out in Australia (Farish, 1984).

Research and debate would appear to be urgently needed into such issues in calibration as:

1. treatment of omitted responses;
2. treatment of not-reached responses;
3. effects of guessing where only two or three alternatives are provided;
4. treatment of misfitting persons in calibration;
5. magnitude of fit statistics for identifying misfitting persons;
6. magnitude of fit statistics for identifying misfitting items;
7. interpretation of partial credit parameters;
8. inclusion or exclusion of items which are biased for particular subgroups, and
9. minimum number of items in a subscale for effective calibration.

These sources of error may be regarded, in the main, as **instrumental errors**. However, the issue of bandwidth also involves **intrinsic errors**, in so far as the particular characteristic under survey has many different manifestations. While the scale formed by Rasch measurement procedures is considered to be independent of the items employed, it would seem necessary that a sufficient range of manifestations of a characteristic should be assessed, and without the use of items that merely supply redundant information.

The use of multiple choice test items and constructed response items, with carefully specified guidelines for scoring, serve to reduce the effects of **observational errors**. However, the move towards embedded assessment, in which teachers embed their assessment procedures within their daily teaching in a classroom, introduces substantial observational error into the measurement process. Research is urgently needed into the nature and magnitude of these observational errors. Nevertheless, it is frequently argued that multiple choice and constructed response test items

reduce the bandwidth of the aspects of performance or the characteristic being assessed and subsequently the range of skills on which instruction is provided. The balance between **bandwidth** and **fidelity** must be given greater consideration as the use of Rasch scaling procedures is more widely employed in the assessment of student performance.

### CONCLUSION

While this paper has addressed issues concerned with errors of measurement and sampling in testing programs, it is necessary to recognize the marked contribution that advances in educational measurement have made and are making to education, particularly in Australian schools. The emphasis has turned during recent decades from innovation and the liberation of teachers from the dominating effects of public examinations to the advancement of student learning and development in which growth in student performance is recorded on profiles each with a scale of performance. These scales of performance not only relate to the areas of the curriculum and the strands within those areas, but also the instruction and testing provided across the grades of schooling and the learning outcomes attained by individual students. Underlying these scales of performance is the principle of strong and meaningful measurement. As a consequence it is becoming possible for teachers and school principals to report to students, their parents, the school community and the community at large the extent of learning that is taking place in schools. Of particular importance, however, is the information given to individual students in order to show them in clearly identifiable terms the growth that they have achieved over a particular period of time as a result of their efforts in the classroom and at school. It is also important to recognize that the scales of learning extend across all levels of schooling and beyond. Learning does not end at the completion of schooling or tertiary education, but extends throughout life as opportunities for lifelong learning and development are followed.

### REFERENCES

- Adams, R. J. & Khoo, S. T. (1993). *QUEST: The Interactive Test Analysis System*. Melbourne:ACER
- Afrassa, T. M. (1998). *Mathematics Achievement at the Lower Secondary School Stage in Australia and Ethiopia: A Comparative Study of Standards of Achievement and Student Level Factors Influencing Achievement*. Unpublished PhD thesis, The Flinders University of South Australia, Adelaide, Australia.
- Afrassa, T. M. & Keeves, J. P. (1997). Changes in Students' Mathematics Achievement in Australian Lower Secondary Schools. Paper presented at the AARE Conference, Brisbane, 30 November to 4 December 1997.
- Brick, J. M., Broene, P., James, P. & Severynse, J. (1997). *A User's Guide to WesVarPC*. (Version 2.11). Boulevard: Westat, Inc.
- Bryk, A. S. Raudenbush, S. & Congdon, R. (1996). *HLM Hierarchical Linear and Non-Linear Modeling with HLM/2L and HLM/3L Programs*. Chicago, ILL.: Scientific Software International.
- Cohen, J. (1988). *Statistical Power Analysis for the Behavioral Sciences* (2<sup>nd</sup> edn.) Hillsdale, N.J.: Erlbaum.
- Cronbach, L. J. (1960). *Essentials of Psychological Testing*. New York: Harper and Rowe.
- Farish, S. J. (1984). *Investigating Item Stability*, (Occasional Paper No. 18). Hawthorn, Vic: ACER.

- Husén, T. (ed.), (1967). *International Study of Achievement in Mathematics*. Stockholm: Almqvist & Wiksell (2 vols).
- Keeves, J. P. (1966). *Students' attitudes concerning mathematics*. Unpublished MEd thesis, University of Melbourne.
- Keeves, J. P. & Schleicher, A. (1992). Changes in Science Achievement. In J P Keeves (ed.), *The IEA Study of Science III: Changes in Science Education and Achievement: 1970 to 1984*. Oxford, Pergamon Press, pp. 263-290.
- Kish, L. D. (1957). Confidence intervals for clustered samples. *American Sociological Review*, 22, 154-165.
- Lokan, J., Ford, P. & Greenwood, L. (1996). *Maths and Science on the Line: Australian Junior Secondary Students' Performance in the Third International Mathematics and Science Study*. Melbourne: ACER.
- Morgan, G. (1979). *A criterion-referenced measurement model with corrections for guessing and carelessness*. (ACER Occasional Paper 13) Hawthorn, Victoria: ACER.
- Peaker, G. F. (1975). *An Empirical Study of Education in Twenty-One Countries: A Technical Report*. Stockholm: Almqvist & Wiksell International.
- Radford, W. C. (1951). *English and Arithmetic for the Australian Children*. Melbourne: ACER.
- Rasbush, Healy, M., Browne, B., & Cameron, R. (1998). *MlwiN1.02*. London, Multilevel Models Project, University of London.
- Ross, K. N. (1978). Sample design for educational survey research. *Evaluation in Education*, 2(2), 105-95.
- Ross, K. N. (1991). *Sampling Manual for the IEA International Study of Reading Literacy*. Hamburg, Germany: IEA Reading Literacy Coordinating Centre.
- Rust, K. & Ross, K. N. (1997). Sampling in survey research. In Keeves J P (ed.) *Educational Research, Methodology, and Measurement: An International Handbook*, (2nd ed.), Oxford: Pergamon, pp. 663-670.
- Rust, K. (1985). Variance estimation from complex estimators in sample surveys. *Journal of Official Statistics* (4): 381-97.
- Schleicher, A. (1994). Adjustment for Age Differences (Appendix G). In W. B. Elley (ed.) *The IEA Study of Reading Literacy: Achievement and Instruction in Thirty-Two School Systems*. Oxford: Pergamon, pp. 257-261.
- Wu, M. L., Adams, R. J. & Wilson, M. R. (1998). *CONQUEST: Generalised Item Response Modelling Software*. Melbourne, Vic.: ACER.

# The change of structural, perception and attitudinal dimensions in information technology implementation processes

---

**I Gusti Ngurah Darmawan**

Flinders Institute of Public Policy and Management

Paper presented at the Educational Research Conference - 30 November 2000

*This paper provides an empirical assessment of the impact of Information Technology (IT) implementation, as a learning process, on the people who use computers or the products of computers in the performance of their daily activities. In particular, this study examines the changes in those people's perception of structural dimensions (the level of centralization and formalization), their perception of IT attributes (belief compatibility, work compatibility, relative advantage, complexity, and observability), and their attitudes toward IT (attitude toward change, and computer related anxiety). This study examines both direct changes produced by these constructs and their indirect changes through IT usage, user satisfaction, and user performance as mediating variables. The results show that small changes occurred between the paired constructs of centralization, formalization, belief and attitude. Meanwhile, the path coefficients of observability, complexity, and anxiety indicate that they have experienced changes of medium size; and the path coefficients of compatibility and relative advantage indicate that large changes occurred. Most of the relationships recorded are due to the direct effects of the initial measures while the indirect effects through usage, satisfaction, and performance show only small influences.*

## INTRODUCTION

In the present era of globalisation, innovations in information technology (IT), centered in telecommunications and informatics, have had very substantial effects on communities and businesses. The availability of ever cheaper and more powerful personal computers, combined with the capability of telecommunication infrastructures have put increasing power into the hands of a greater number of people in organizations (Kraemer & Dedrick, 1997; Rischard, 1996; Willcocks, 1994).

However, two powerful and contrary images are widely linked with the use of IT in organizations. In one view, this technology is the great problem solver, producing important gains in the efficiency and effectiveness of people in their work. In the contrasting view, the technology is a problem generator, an expensive and disruptive technology that has often failed to match its promise in many of the actual tasks to which it has been applied, has generated many negative effects on end users, namely, people who use computers or their products in the performance of their daily activities, and sometimes seems uncontrollable by these end users (Danzinger & Kraemer, 1986).

IT usage and user satisfaction are considered to be two major factors that impact on the success of an IT implementation (Kim, Suh, & Lee, 1998). They have been noted as indicators of IT acceptance by a number of studies (Baroudi, Olson, & Ives, 1986; Gelderman, 1998; Mahmood, 1995; Taylor & Todd, 1995; Thompson, Higgins, & Howell, 1991). Furthermore, IT utilization and user attitude toward technology have an impact on performance (Woodroof & Kasper, 1998; Goodhue & Thompson, 1995). Therefore, IT implementation is looked at from three angles: IT usage, user satisfaction, and user performance.

This paper provides an empirical assessment of these issues, analyzing the impact of the IT implementation processes on end users. In particular, this study examines the changes in end users' perceptions of structural dimensions (the level of centralization and formalization), the changes in end users' perceptions on IT attributes (belief compatibility, work compatibility, relative advantage, complexity, and observability), and the changes in end users' attitudes toward IT (attitude toward change, and computer related anxiety). This study examines both direct changes produced by these constructs and their indirect changes through IT usage, user satisfaction, and user performance as mediating variables

### RESEARCH FRAMEWORK AND RESEARCH MODEL

Research findings in adoption and diffusion of new technology indicate various sets of variables that affect the successful implementation of IT. Researchers have defined these variables in various ways or they have grouped them differently. Nevertheless, all of these approaches in one form or another consider the environmental, human, organizational, and the technological factors to be potential factors that affect the successful adoption and implementation of IT.

This study focuses on end users' perceptions of organizational structure, end users' perceptions of the attributes of IT, and end users' attitudes toward IT and how they change after the IT implementation. For the purpose of this study, a conceptual model for the change of structural, perception and attitudinal dimensions in information technology implementation processes, as shown in Figure 1, was built.

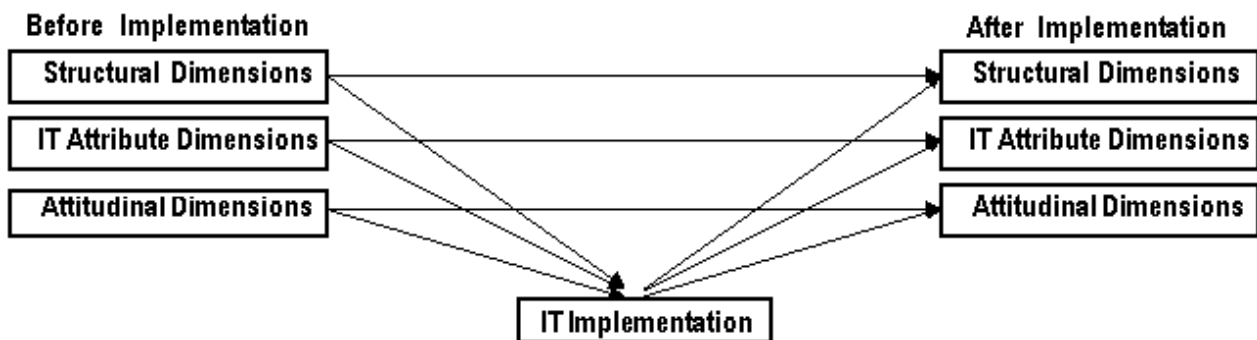

**Figure 1. Conceptual model**

### Structural Dimensions

The major dimensions studied under the category of structural dimensions have been centralization, formalization, complexity, and organizational size. Two of them used in this study are: centralization and formalization. According to Lai and Guynes (1997, p.148), centralization is "the degree to which power and control are concentrated in the hands of relatively few individuals". There have been mixed views about the effects of centralization; higher degrees of this dimension have negative effects on the adoption of innovation due to severe constraints on autonomy and authority (Lai & Guynes, 1997), whereas positive effects have also been observed

because, under such circumstances, it may be easier to impose the adoption and implementation of innovations (Rogers & Shoemaker, 1971; Zatlman, Duncan & Holbeck, 1973). However, many studies (Moch & Morse, 1977; Goslar, 1993, cited in Lai & Guynes, 1997) have suggested that a centralized organization can be expected to correlate negatively with the decision to adopt those innovations that are more compatible with the interests of lower-level personnel.

Formalization is another attribute of organizations believed to explain significant differences in the adoption of technologies. Formalization is the degree to which an organization emphasizes rules and procedures in the role of performance of its members. It is believed that formalization has a negative effect on the adoption of innovation (Bingham, 1976; Lai & Guynes, 1997).

### **Technology Attribute Dimensions**

Despite the importance of this domain, particularly for technological innovations, past research has been plagued with a number of conceptual and methodological problems as articulated by Tornatzky and Klein (1982). Over 25 attributes (e.g. compatibility, complexity, costs, risk, trialability, relative advantage, profitability) have been studied. One of the most comprehensive treatments of this subject area was conducted by Rogers (1983). His summary of research in a variety of disciplines indicated the five most important attributes of innovations: (a) relative advantage, (b) compatibility with existing operational practices and values, (c) complexity, (d) trialability, and (e) observability (Rogers, 1983).

Relative advantage, as the label implies, depicts the degree to which an innovation is perceived as being better than the existing situation it supersedes or superior to other competing alternatives, and the extent to which it can provide more benefits (Rogers, 1983). This has been evaluated on many dimensions such as profitability, productivity, time saved, and hazards removed.

Compatibility refers to the degree of fit the innovation has with the adopting organizational unit and has been conceptualized to encompass two aspects: (a) fit or match with current technical and operational practices, and (b) fit with or conformance to the prevailing beliefs, attitudes, needs of receivers and value system (culture) (Rogers & Shoemaker, 1971). A greater degree of compatibility on both the dimensions has generally been observed to generate more favourable attitudes and behaviour towards adoption (Ettlie & Vellenga, 1979). However, some negative findings have also been noted (Fliegel & Kivlin, 1966).

The complexity of an innovation is “the degree to which an innovation is perceived as relatively difficult to understand and use” (Tornatzky & Klein 1982, p. 35). Most of the past research has demonstrated a negative effect of complexity on adoption and implementation of innovation (Fliegel & Kivlin, 1966).

Trialability is “the degree to which an innovation may be experimented with on a limited basis” (Tornatzky & Klein 1982, p. 38). Theoretically, innovation that can be tried on the instalment plan is adopted and implemented more often and more quickly than less trialable innovations.

Observability is the “degree to which the results of an innovation are visible to others” (Tornatzky & Klein 1982, p. 38). The more visible the results of an innovation, the more likely the innovation is quickly adopted and implemented.

### **Attitudinal Dimensions**

This category draws links from the personality theory of organizational behaviour with an underlying premise that the characteristics of individuals can be used to predict adoption behaviour. At the individual level, the most important attitudinal factors are fear of change (Mohr,

1969; Peterson & Peterson, 1988) and the feeling of anxiety (Peterson & Peterson, 1988; Anderson, 1996).

Fear of change is expressed through the concern of people about safety, security or self-esteem. It is manifested primarily through worrying about loss of skill or possible replacement by more efficient equipment. Loss of power and absence of an obvious personal benefit may also be a sufficient ground for rejection. The second attitudinal factor, anxiety, is a natural feeling of uneasiness when exploring and facing unfamiliar terrain.

### **IT Implementation**

Most researchers have argued that IT usage is one of the primary variables that affect an individual's performance. IT usage is frequently used as a surrogate for evaluating IT success and has occupied a central role in IT implementation research. IT usage has been noted as an indicator of IT acceptance (Gelderman, 1998). It reflects the interaction of IT with the users. Most studies have argued that IT usage is one of the primary variables which affects an individual's performance (DeLone & McLean, 1992; Goodhue & Thompson, 1995).

Another dimension which is regarded to be a major factor in measuring implementation success is user satisfaction with the technology performance. User satisfaction reflects the interaction of IT with users. A number of researchers have found that user satisfaction has a positive association with IT usage (Baroudi et al., 1986; Cheney et al., 1986; Doll & Torkzadeh, 1991; Thompson et al, 1991; Goodhue & Thompson, 1995; Gelderman, 1998).

Because the impacts of IT on organizations are so pervasive in postindustrial society, it is useful to define the domains of IT impacts that are the focus of this study. There are impacts of IT on collectivities, such as the work group, the department, the organization, or even the society, and impacts on individuals. This study focuses on the impacts of IT utilization on individuals who work in governmental agencies in terms of efficiency, effectiveness, and appropriateness (Kahen, 1995; Sharp, 1996; Sharp, 1998). DeLone and McLean (1992) in their study showed that user satisfaction affects user performance. Their findings were also supported by Gelderman (1998), who found that the relationship between user satisfaction and user performance was significant.

From these theories, a research model was developed for the change of structural, perception and attitudinal dimensions in information technology implementation processes, as shown in Figure 2.

### **MEASURES**

#### **Centralization**

Centralization refers to where the locus of decision making is located near the top of the management level of the organization and the consequent lack of freedom at the various levels of the organizational hierarchy in making important organization-related decisions (Hage & Aiken, 1967, Lay & Guyness, 1997). This study used four items to capture the locus of decision making responsibility.

#### **Formalization**

Formalization is the amount of written documentation that directs, guides, and controls employees (Lay & Guyness, 1997). Three items were used to capture the formalization level of the organization.

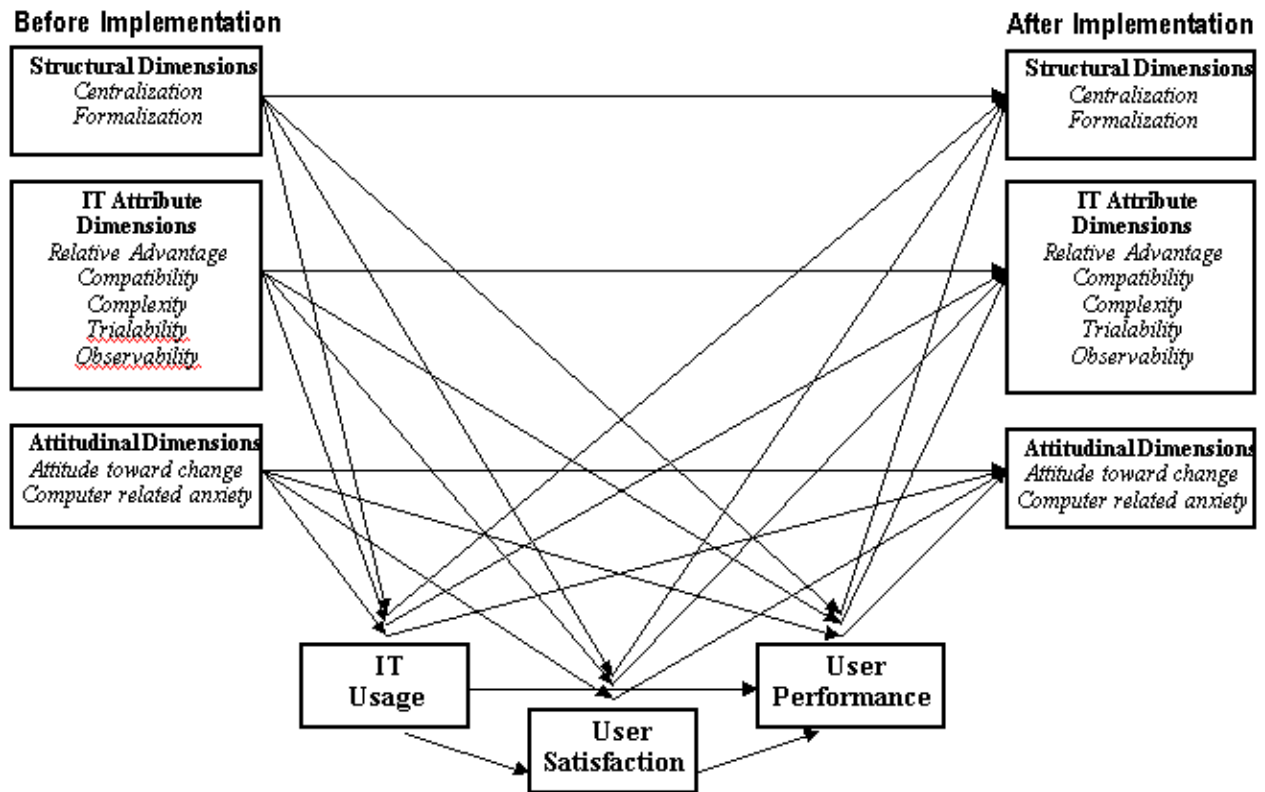

Figure 2. Research model

### Relative Advantage

The technology has to offer clear benefits to the organizational members in order to be adopted. IT has to have a comparative advantage over previous practice used. Some measurements for relative advantage have been developed by various researchers (Danziger & Kraemer, 1986; Down & Mohr, 1976, 1979; Iacovau et.al, 1995; Moore and Benbasat, 1991; Panizzolo, 1998; Rogers, 1983; Rogers & Shoemaker, 1971; Tornatzky & Klein, 1982). Danziger and Kraemer (1986) summarized the benefits that might be anticipated from the use of computing in organizations. They classified the benefits into three categories, such as information benefits, efficiency benefits, and effectiveness in serving the public. The information benefits were measured by gathering the assessments of end users regarding the extent to which IT had improved four aspect of their information environment: (a) the speed with which information can be obtained; (b) the ease of access to information; (c) the availability of new information; and (d) the timeliness of the information. The efficiency benefits were measured by assessing the extent to which IT had reduced departmental staff, had reduced the cost of departmental operations, and had enabled the department to increase its work volume without corresponding increases in cost. Lastly, effectiveness was measured by including end user evaluation of whether IT had improved the department’s effectiveness in serving the public.

### Compatibility

IT is more likely to be used if compatible with organizational members’ existing values and beliefs, needs and previous experiences regarding computerized technology. Three dimensions of compatibility that are used in this study are: (a) personal values and belief compatibility, (b) workstyle compatibility, and (c) previous experience compatibility.

The use of four items for the measurement of workstyle compatibility has been proposed by Moore and Benbasat (1991). The same items were used in this study. In addition, one item on

previous experience and four items on values and beliefs are employed to capture the two other dimensions of compatibility.

### **Complexity**

It is quite obvious that new technologies or even ideas that are simpler to understand are more readily and rapidly accepted than those that require the adopting organization to develop new skills and understanding (Rogers, 1983). The complexity is associated with difficulty to understand and to use the technology. Two items dealing with the difficulty experienced in understanding and using the technology were employed to operationalize technological complexity.

### **Trialability**

Innovation that can be tried on an instalment plan is adopted more quickly (Rogers & Shoemaker, 1971). The trialability was operationalized by using two items.

### **Observability**

Organizational members who have been exposed to IT, hypothetically, are more likely to adopt it. The observability is defined as the opportunity to try out or view the technology (Rogers & Shoemaker, 1971). Two items were used to operationalized observability.

### **The Attitude Toward Change**

The items that were used to measure user attitude toward change are based on the Kirton Adaptor-Innovator Inventory (Kirton, 1984). The KA-I Inventory consists of 32 questions, using a five-point scale, measuring individual creativity in terms of the form or style of creativity behaviour.

### **Computer Related Anxiety**

Computer related anxiety has been found to be a detrimental factor for engagement in using computerized technology. A feeling of apprehensiveness may result in rejection of the source of uneasiness. Anderson (1996) developed a ten-item measure of computer related anxiety. Five items out of the ten items were adopted for this study.

### **Utilization**

The IT usage scale is taken from Thompson et. al. (1991). Three dimensions are suggested for IT usage: (a) intensity of use, (b) frequency of use, and (c) diversity of software packages used. The first two dimensions are also supported by Geldermen (1998). For the purpose of this study, four different measures were used to assist in capturing IT usage, namely: (a) frequency of use, (b) time of use, (c) number of tasks for which the system is used by employees, and (d) number of computer applications used by employees.

### **User Satisfaction**

Starting with the user satisfaction measure originally developed by Bailey and Pearson (1983), Ives et al. (1983) produced a shorter form by excluding 26 items from the original 39-item instrument. Raymond (1985) also adapted the instrument and developed a 20-item questionnaire. Doll and Torkzadeh (1988, 1991, 1994) developed another instrument. They promoted a 12-item scale to measure user satisfaction. The scale is a measure of overall user satisfaction that includes a measure of the satisfaction of the extent to which computer applications meet the end-user's needs with regards

to five factors, namely (a) content, (b) accuracy, (c) format, (d) ease of use, and (e) timeliness. The use of these five factors with the 12-item instrument developed by Doll and Torkzadeh (1988, 1991, 1994) as a general measure of user computing satisfaction has been supported by Harrison and Rainer (1996). In addition to these five factors, two more factors were adopted from Palvia's (1996) measurement of small business user satisfaction. The two additional factors were hardware and software adequacies.

### **User Performance**

This study only concentrates on evaluating the impacts of IT utilization and user satisfaction on user performance. User performance is measured in terms of efficiency, effectiveness, and appropriateness (Kahen 1995; Sharp 1996; Sharp 1998). The importance of appropriateness has also been considered by Kahen (1995). He argued that the problems and complexity of information technology transfer to developing countries are affected by the existing local and national characteristics. Therefore a successful IT transfer should involve appropriateness criteria. Some items that have been developed by Moore and Benbasat (1991) were modified for this study.

### **DATA COLLECTION**

The total number of agencies that participated in this study were 153 government agencies across all regions of Bali, Indonesia. Those 153 agencies employed a total of 10,034 employees. Of these, 1,427, or approximately 14 per cent, used information technology in their daily duties. They may be considered end users. A total of 1,187 questionnaire forms were distributed during the beginning of August 1999. By January 2000, a total of 957 completed questionnaire responses had been returned (81% return rate).

From the total of 957 respondents, 61.5 per cent of them were male. In terms of age, the largest group of respondents was those between the ages of 31-40 years (40.2%). The second and the third largest group in the study were employees in the age group 41-50 years (25.6%) and the age group 21-30 years (23.7%) respectively. In total, 89.5 per cent of the respondents were in the age group range 21-50 years. Almost two-thirds of the government employees who participated in this survey (66.2%) had at least a tertiary diploma or a university degree. About 30 per cent had only completed their high school education. In terms of computer training and computer experience, almost one-third of them (32.8%) had never completed any training. Most of them had attended some sort of software training (64.9%), a small number of them (4.8%) had experience in attending hardware training, and only 2.5 per cent had experience in both forms of training. Among the respondents, most of them (80.75%) were operators. Only 3.9 per cent and 1.4 per cent had the experience of being a programmer and system analyst respectively. More than half of the questionnaire responses were completed by staff level members (51.2%), while most of the remaining (43.5%) were completed by mid/low managers, and only 4.8 per cent were completed by the top managers in the organizations.

### **DATA ANALYSIS**

The data collected were analyzed using SPSS ver.10 (SPSS, 1986) and AMOS ver. 4.01 (Arbuckle & Wothke, 1999). SPSS was mainly used to do univariate and bivariate analyses. While AMOS was used to model the change and to explain the structure or pattern among a set of latent (unobserved or theoretical) variables, each was measured by one or more manifest (observed or empirical) variables.

## Validity

Construct validity testifies as to how well the results obtained from the use of the measure fits the theories around which the test is designed. The construct validity is usually verified through factor analytic techniques examining the items representing a particular construct that have high factor loadings on one construct and low loadings on all other constructs (Stevens, 1996). All the items representing one or more of the research constructs belonging to each domain were subjected to factor analysis.

## Reliability

The reliability of measurement indicates the stability and consistency with which the instrument is measuring the concept (Sekaran, 1992). In this study, the internal consistency reliability of the scales is measured by the Cronbach alpha coefficient. The factors extracted from the exploratory factor analysis were subjected to reliability checks for further simplification. From the results of these analyses, the research model was then modified accordingly.

## Paired Sample t-test

In order to understand the change of each item used, a paired sample t-test was employed. Each item used a scale that ranged from not at all (0) to a very large extent (5). Most of the items changed significantly (with  $|t\text{-value}| > 2$ ) except for items CEN4 and DIUS. According to Cohen (1992), the effect size (ES) for the difference between independent means ( $d$ ) is expressed in units of the within population standard deviation; and the lower boundaries for the small, medium, and large ESs are  $d=0.20$ ,  $0.50$ , and  $0.80$ . The changes of the mean values are summarized in Table 1.

**Table 1. The Difference between paired item means**

No	Constructs	Change Description
1	Centralization	small increase for all items
2	Formalization	small increase for all items
3	Belief	small increase for four items and medium increase for one item
4	Relative Advantage	medium increase for all items
5	Compatibility	medium increase for two items and large increase for one item
6	Complexity	small increase for all items
7	Observability	medium increase for all items
8	Attitude Toward Change	small increase for all items
9	Computer Related Anxiety	small decrease for all items

## Trial on Direct and Indirect Changes

A series of further analyses to explore the nature of change were undertaken using AMOS ver.4.01. First, a one to one direct change model was built as can be seen in Figure 3. In order to reduce the number of variables in the model, the 32-item measure for attitudes toward change were grouped into five factors (in concordance with the factor analysis result). A principal component score for each of these five factors was, then, extracted. The maximum likelihood estimations (MLE) for unstandardized and standardized values of the path coefficients and the corresponding critical ratios were estimated. The next step was to assess the goodness of fit of the model. Chi-square divided by the number of degrees of freedom was used as the goodness of fit indicator. A value of the ratio of a chi-square to the number of degrees of freedom which is less than 5 can be considered adequate for a large model (Al-Gahtani & King, 1999).

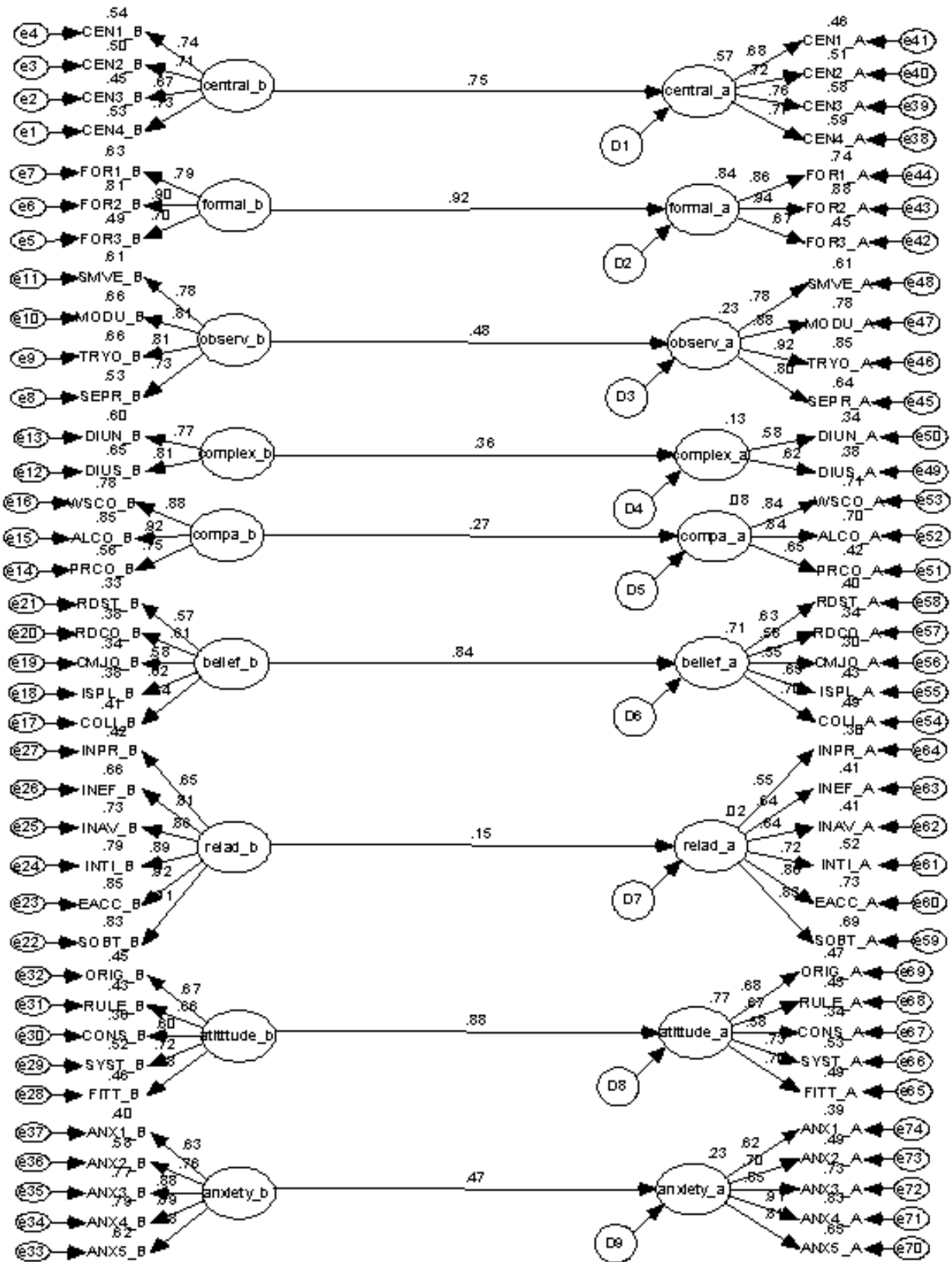

Figure 3. Direct change model

Other criteria are the goodness of fit index (GFI) and the adjusted goodness of fit index (AGFI), which approach unity the better the model fits the data. A third criterion is the root mean square residual (RMSR). This is a measure of the average of the residual variances and covariances, and values close to zero indicate a good model fit. Using these test criteria, the value of  $\chi^2/DF$  ratio,

GFI, AGFI, and RMSEA of 7.8, 0.612, 0.589, and 0.084 respectively indicate that this model does not fit the data very well. This is reasonably acceptable because this model only tries to impose one-to-one relationships by ignoring other possible paths. From the measurement model it can be seen that none of the indicators has a factor loading less than 0.4 which means that all of the indicators have a reasonably high loadings on each latent variable. From the structural model, it can be inferred that a higher path coefficient indicates that less change occurred between the before and the after IT implementation constructs. The path coefficients of formal\_b- formal\_a, central\_b-central\_a, belief\_b-belief\_a, and attitude\_b-attitude\_a are 0.92, 0.75, 0.84, 0.88 respectively. These relatively large coefficients indicate that only small changes occurred between those paired constructs. The path coefficients of observ\_b- observ\_a, anxiety\_b- anxiety\_a, and complex\_b-complex\_a are 0.48, 0.47, 0.37 respectively. These indicate that medium changes occurred. The path coefficients of compa\_b-compa\_a and relad\_b-relad\_a are 0.27 and 0.15 respectively. These relatively small coefficients indicate large changes occurred. The variances explained ( $R^2$ ) for the exogenous variables are as follows: central\_a (0.57), formal\_a (0.84), observ\_a (0.23), complex\_a (0.13), compa\_a (0.08), belief\_a (0.71), relad\_a (0.02), attitude\_a (0.77) and anxiety\_a (0.23).

Second, a model of indirect changes through IT usage, user satisfaction, and user performance as mediating variables was build as can be seen in Figure 4. Using the same test criterion, the value of  $\chi^2/DF$  ratio, GFI, AGFI, and RMSEA of 5.699, 0.601, 0.582, and 0.070 respectively indicate that this model also does not fit the data very well. This is also reasonably acceptable because the model only tries to impose the indirect changes by ignoring other possible paths. From the measurement model, it can be seen that even though the structure of the loadings change slightly, none of the indicators has a factor loading less than 0.4 which means that all of them have a reasonably high loading on each latent variable.

Central\_b, formal\_b, belief\_b, and attitude\_b have a positive influence on satisfaction with the unstandardized path coefficients of 0.06 (CR=2.28), 0.144 (CR=6.62), 0.08 (CR=2.59), 0.22 (CR=6.89) respectively, while relad\_b has a negative influence on satisfaction with an unstandardized path coefficient of -0.09 (CR=-5.21). This negative influence indicates that the higher the initial perception of relative advantage of IT the less satisfied is the user. In other words, the higher the expectation the lower is the satisfaction.

In turn, user satisfaction has positive effects on central\_a, formal\_a, observ\_a, compa\_a, belief\_a, attitude\_a with the unstandardized path coefficients of 0.25 (CR=4.16), 0.64 (CR=9.96), 0.42 (CR=7.59), 0.17 (CR=3.47), 0.20 (CR=4.28), 0.24 (CR=5.41), 0.32 (CR=7.39), and a negative effect on anxiety\_a with the coefficient of -0.17 (CR=-2.75) which means the more the users are satisfied the less they feel anxious about computer usage.

The variances explained ( $R^2$ ) for exogenous variables are as follows: usage (0.21), satisfaction (0.17), performance (0.20), central\_a (0.04), formal\_a (0.28), observ\_a (0.22), complex\_a (0.01), compa\_a (0.13), belief\_a (0.11), relad\_a (0.14), attitude\_a (0.24) and anxiety\_a (0.03).

From these two separate analyses, it was fund that the models do not fit the data well. In addition, it was also difficult to combine the two into one model and to trim the more complex model. In order to get a more detailed model that fits the data, three sub-models namely: (a) structural dimensions change model, (b) IT perception dimensions change model, and (c) attitudinal dimensions change model were built. Each separate analysis is discussed in the following sections.

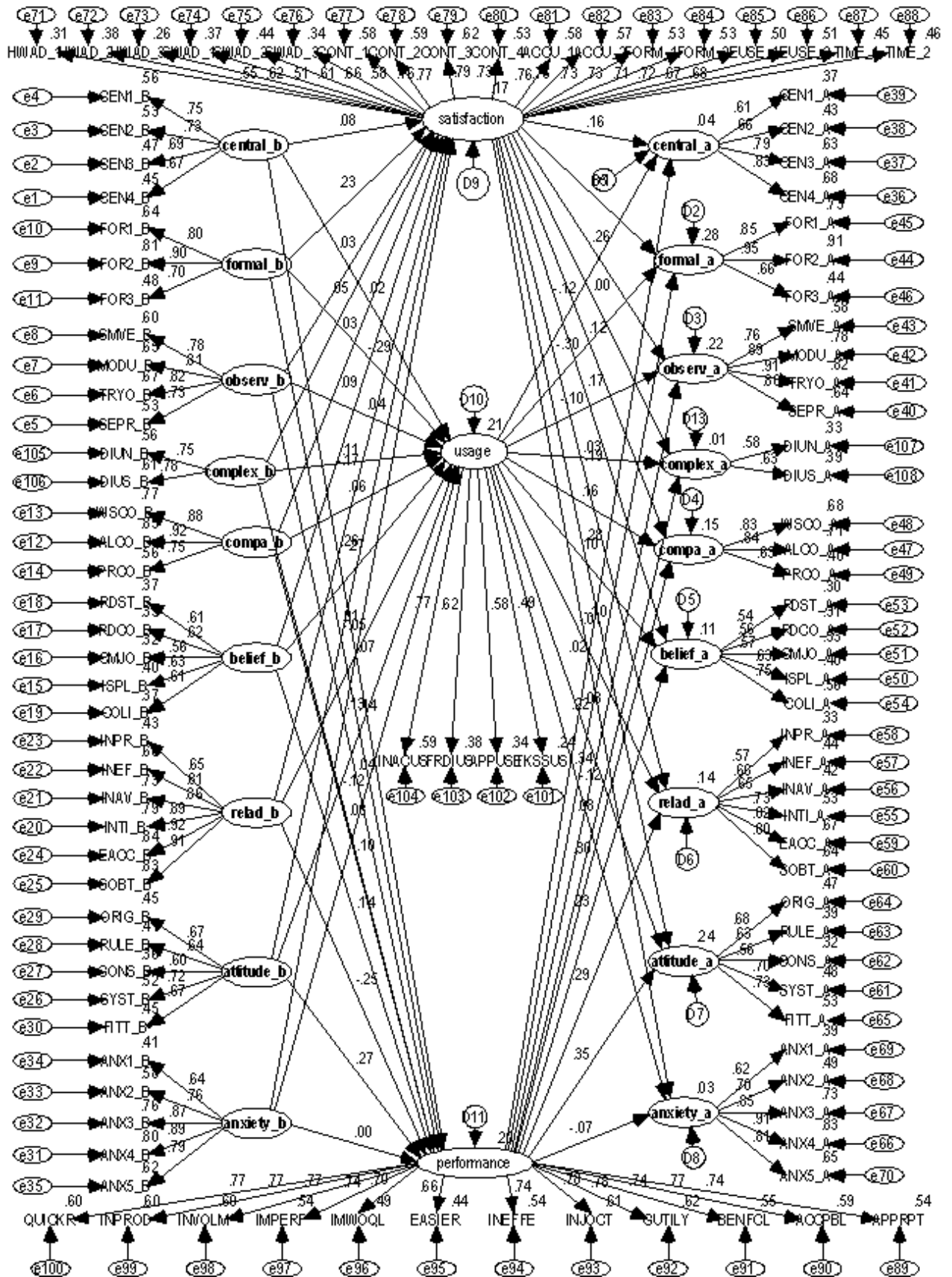
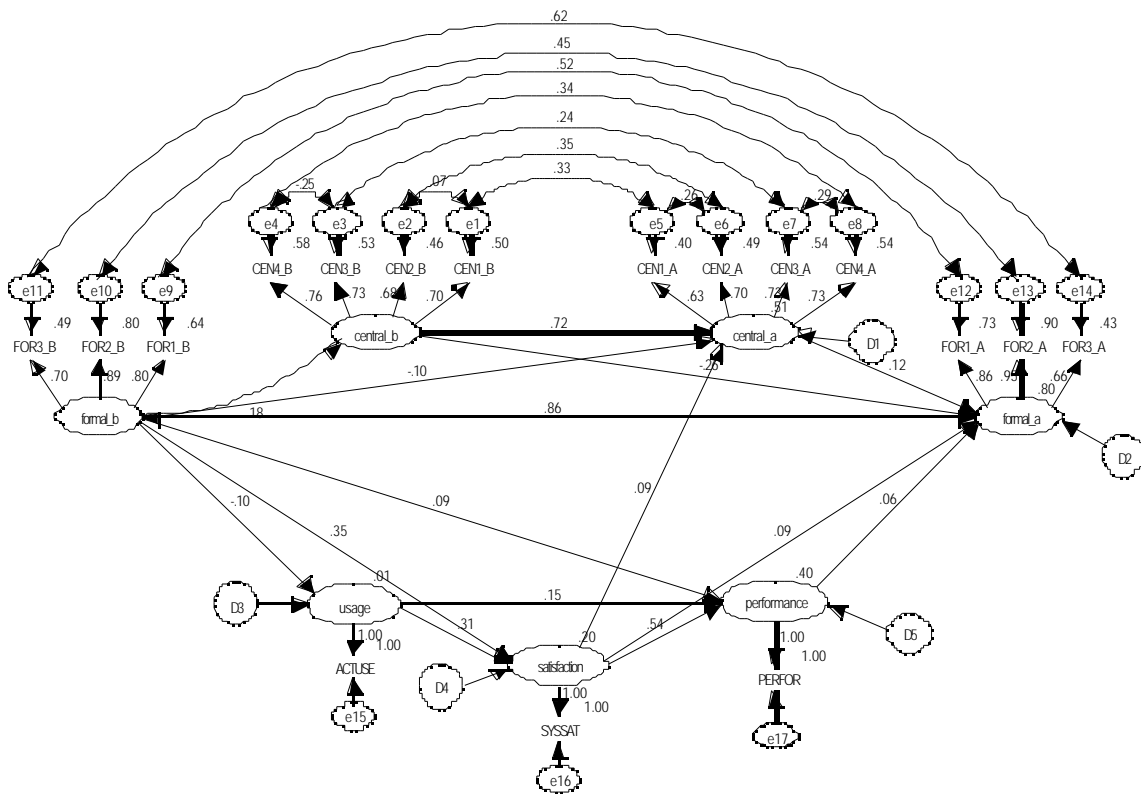

Figure 4. Indirect change model

### Structural Dimensions Change Model

A diagrammatic representation of the final structural change model can be seen in Figure 5. Since the paired error terms represent the unique term of the same indicator on two different measurement occasions, it may indeed be reasonable to assume that they are correlated over time. By adding these correlation along with the correlation between central\_b and formal\_b and the four other correlations (e1-e2, e3-e4, e5-e6, e7-e8), the values of  $\chi^2/DF$  ratio, GFI, AGFI, and RMSEA of 5.625, 0.939, 0.903, and 0.070 respectively indicate this model fits the data reasonably well.



**Figure 5. Structural Dimensions Change Model**

It can be seen in Figure 5, that central\_a and formal\_a are mainly influenced by central\_b and formal\_b with the standardized path coefficients of 0.72 and 0.86 respectively. The influences of the mediating variables are very small. Central\_a is influenced by satisfaction, and formal\_a is influenced by satisfaction and performance with the path coefficients of 0.09, 0.09, 0.06 respectively.

The variances explained ( $R^2$ ) for the endogenous variables are as follows: usage (0.01), satisfaction (0.20), performance (0.40), central\_a (0.51), and formal\_a (0.80).

### IT Perception Dimensions Change Model

A diagrammatic representation of the final IT perception change model is presented in Figure 6. By allowing the paired error terms to be correlated, the model fits the data better. The value of  $\chi^2/DF$  ratio, GFI, AGFI, and RMSEA of 4.028, 0.871, 0.843, and 0.056 respectively indicate that this model fits the data reasonably well.

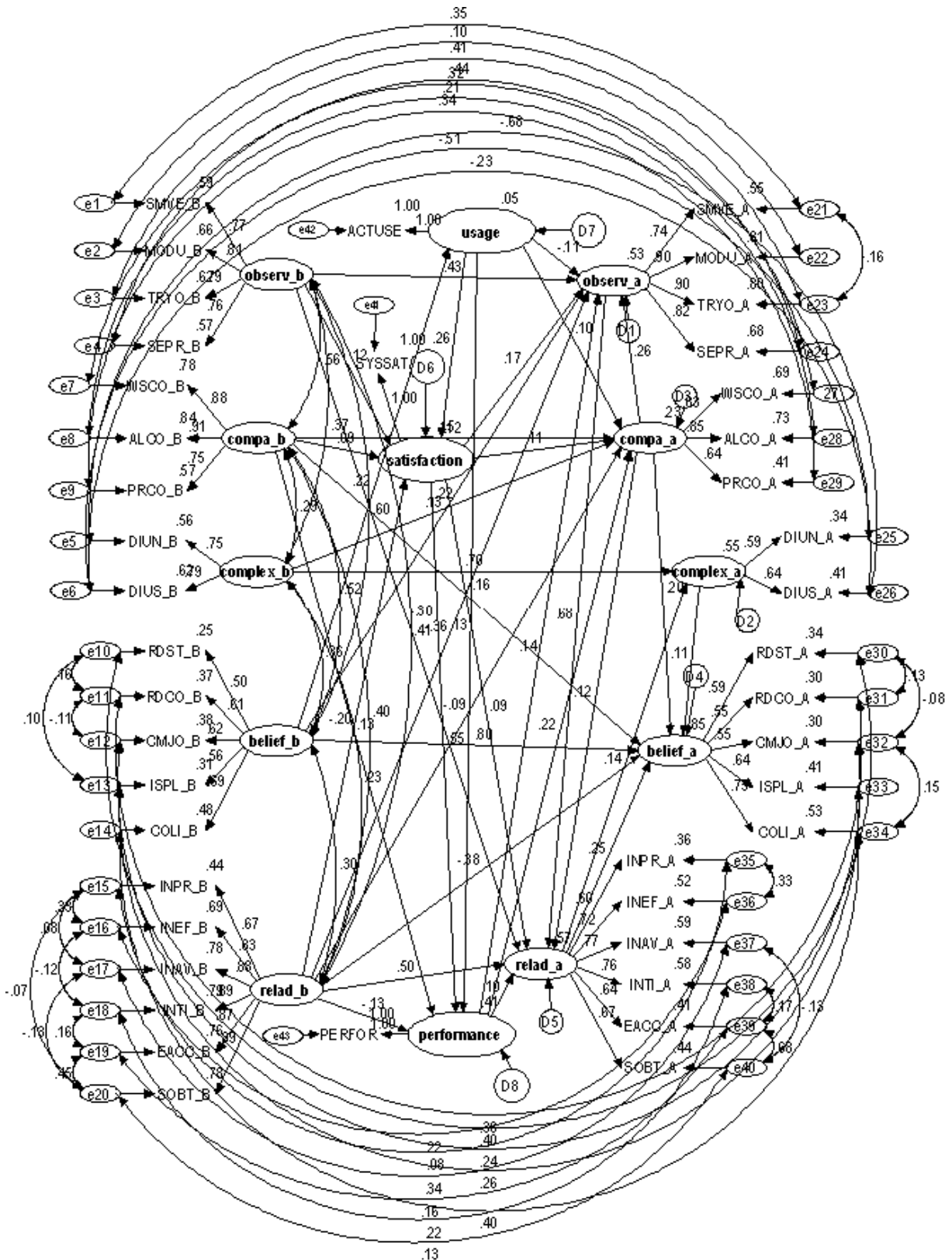

**Figure 6. IT Perception dimension model**

It can be seen in the model that compatibility after implementation (compa\_a) is influenced directly by compa\_b, complex\_b and relad\_b with the path coefficients of 0.15, 0.22, and -0.09

respectively and indirectly through performance, satisfaction and usage with the path coefficients of 0.22, 0.11, and 0.10 respectively. Observability after implementation (observ\_a) is influenced directly by observ\_b, relat\_b, belief\_b, and compa\_a with the path coefficients of 0.43, -0.36, 0.13, and 0.26 respectively and indirectly through satisfaction, performance, and usage with the path coefficients of 0.17, 0.14, and -0.11 respectively. Relative advantage after implementation (relad\_a) is influenced directly by relat\_b, observ\_b, observ\_a, compa\_a with the path coefficients of 0.50, -0.30, 0.69, 0.12 and indirectly through satisfaction and performance with the path coefficients of 0.90, 0.97. Complexity after implementation (complex\_a) is influenced directly by complex\_b and relat\_a with the path coefficients of 0.71 and 0.14 respectively. There are no indirect effects through mediating variables. Belief after implementation (belief\_a) is influenced directly by belief\_b, relat\_b, compa\_b, compa\_a, relat\_a, complex\_a with the path coefficients of 0.80, -0.38, -0.16, 0.20, 0.25, 0.11 respectively.

The variances explained ( $R^2$ ) for the endogenous variables were as follows: usage (0.05), satisfaction (0.12), performance (0.41), observ\_a (0.53), complex\_a (0.55), compa\_a (0.23), belief\_a (0.85), relat\_a (0.77).

### Attitudinal Dimensions Change Model

The final attitudinal dimensions change model is given in Figure 7. The values of  $\chi^2/DF$  ratio, GFI, AGFI, and RMSEA of 3.212, 0.942, 0.923, and 0.048 respectively and they indicate that this model fits the data very well.

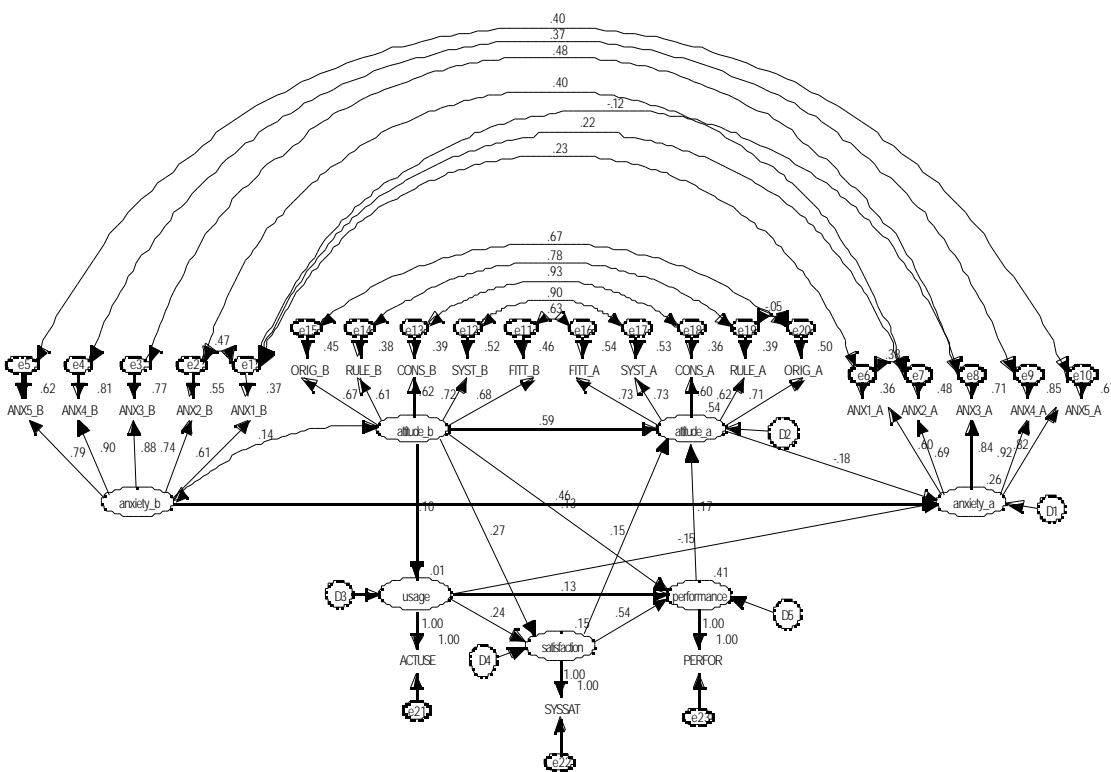

**Figure 7. Attitudinal dimensions change model**

Attitude\_a and anxiety\_a are mainly influenced by attitude\_b and anxiety\_b with the standardized path coefficients of 0.59 and 0.46 respectively. The influences of the mediating variables are relatively small. Attitude\_a is influenced by satisfaction, and performance with the path

coefficients of 0.15 and 0.17 respectively. Anxiety is influenced negatively by usage and attitude\_a with the path coefficients of -0.15 and -0.18 respectively. This means that the higher the usage and the higher the attitude toward change the less anxious the users feel.

The variances explained ( $R^2$ ) for endogenous variables are as follows: usage (0.01), satisfaction (0.15), performance (0.41), attitude\_a (0.54) and anxiety\_a (0.26).

### Combined Model

In order to obtain a complete picture, in which the components of the whole model interact with each other, these three sub models were then combined into one model. Moreover, to simplify the model, a principal component score was extracted for each set of indicators. By allowing the exogenous variables to be correlated with each other, the final result is slightly different as can be seen in Figure 8. Using the same test criterion, the value of  $\chi^2/DF$  ratio, GFI, AGFI, and RMSEA of 3.353, 0.960, 0.925, and 0.050 respectively indicate that this model fits the data very well.

For the structural dimensions, as can be seen in the model, central\_a is only influenced directly by central\_b with the path coefficient of 0.61. Formal\_a is influenced directly by formal\_b, central\_b, and relad\_b with the path coefficients of 0.77, -0.11, -0.14 respectively and indirectly through satisfaction and performance with the path coefficients of 0.11 and 0.06 respectively.

For the IT perception dimensions, compa\_a is influenced directly by compa\_b, complex\_b, relad\_a, and belief\_a with the path coefficient of 0.11, 0.10, 0.17 and 0.23 respectively and indirectly through performance and usage with the path coefficients of 0.16 and 0.10 respectively. Observ\_a is influenced directly by observ\_b, relad\_b, formal\_a and belief\_a with the path coefficients of 0.31, -0.14, 0.37 and 0.25 respectively and indirectly through performance with the path coefficient of 0.18. Relad\_a is influenced directly by relad\_b, observ\_b, observ\_a, and belief\_a with the path coefficients of 0.38, -0.24, 0.53, 0.16 and indirectly through satisfaction and performance with the path coefficients of 0.80 and 0.13 respectively. Complex\_a is influenced directly by complex\_b, relad\_b, and belief\_a with the path coefficients of 0.15, 0.17, and 0.20 respectively. There are no indirect effects through mediating variables. Belief\_a is influenced directly by belief\_b and relad\_b with the path coefficients of 0.69 and -0.26 respectively and indirectly through satisfaction and performance with the path coefficients of 0.12 and 0.06 respectively.

For the attitudinal dimensions, attitude\_a is influenced directly by attitude\_b, formal\_b, formal\_a, and observ\_a with the standardized path coefficients of 0.64, -0.32, 0.41, and 0.09 respectively and indirectly through satisfaction and performance with the path coefficients of 0.07 and 0.09 respectively. Anxiety\_a is influenced directly by anxiety\_b, complex\_b, relad\_b, and complex\_a with the path coefficients of 0.41, -0.12, 0.13, and 0.23 respectively and indirectly through satisfaction and usage with the path coefficients of -0.12, -0.13.

The variances explained ( $R^2$ ) for the endogenous variables are as follows: usage (0.07), satisfaction (0.20), performance (0.41), central\_a (0.38), formal\_a (0.73), observ\_a (0.54), complex\_a (0.10), compa\_a (0.27), belief\_a (0.50), relad\_a (0.43), attitude\_a (0.63) and anxiety\_a (0.28).

### Higher Level Model

In order to simplify the model even further, a higher level model was build as can be seen in Figure 9. Initially, an attempt to combine two structural dimensions (centralization and formalization), five IT perception dimensions (belief, relative advantage, compatibility, complexity, and observability), and two attitudinal dimensions (attitude toward change and computer related

anxiety) into a higher level construct called structure, perception, and attitude was made. However, the structural dimensions and attitudinal dimensions could not be combined due to their small correlations. Finally only the perception dimension could be combined into the perception construct. The value of  $\chi^2/DF$  ratio, GFI, AGFI, and RMSEA of 5.165, 0.933, 0.895, and 0.066 respectively indicate this model fit the data reasonably well.

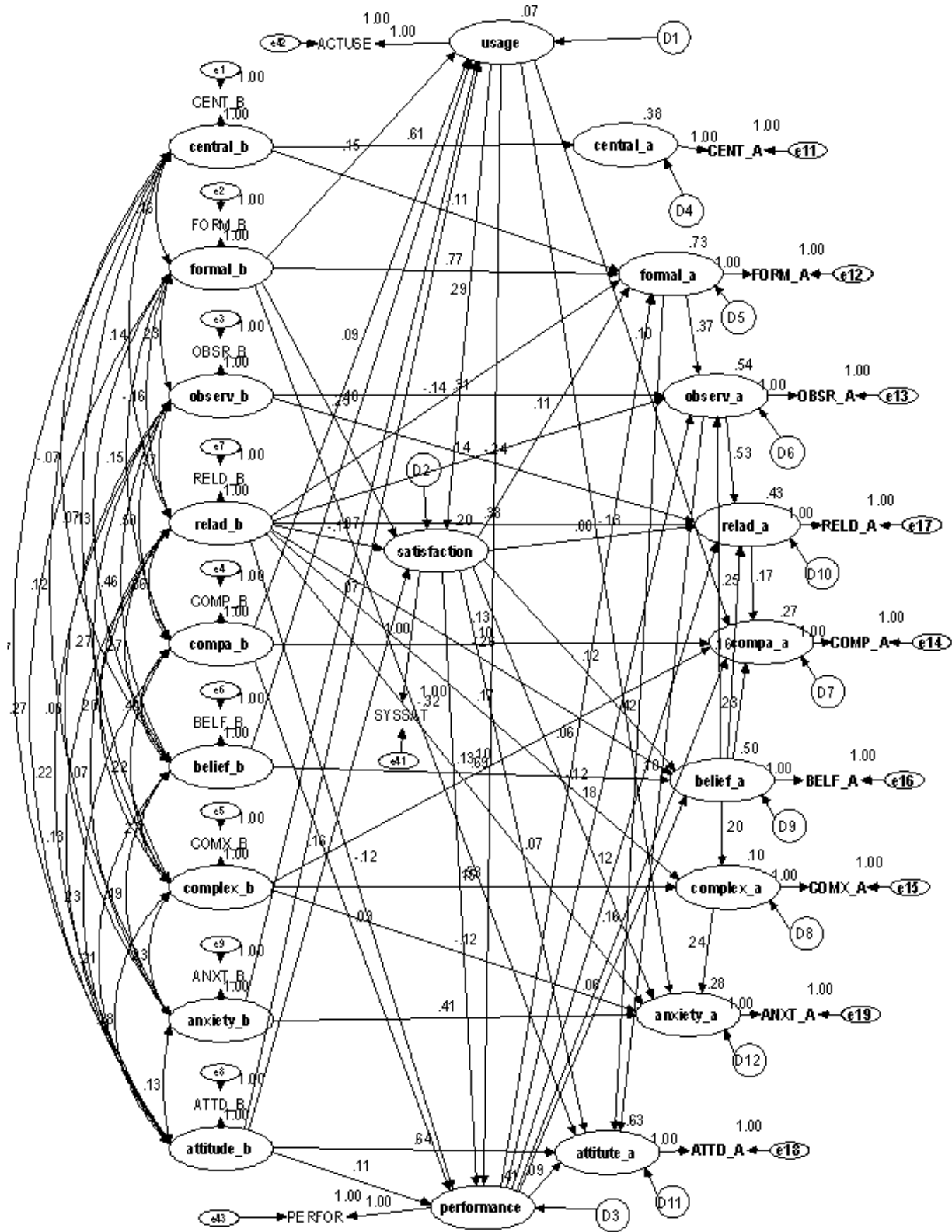
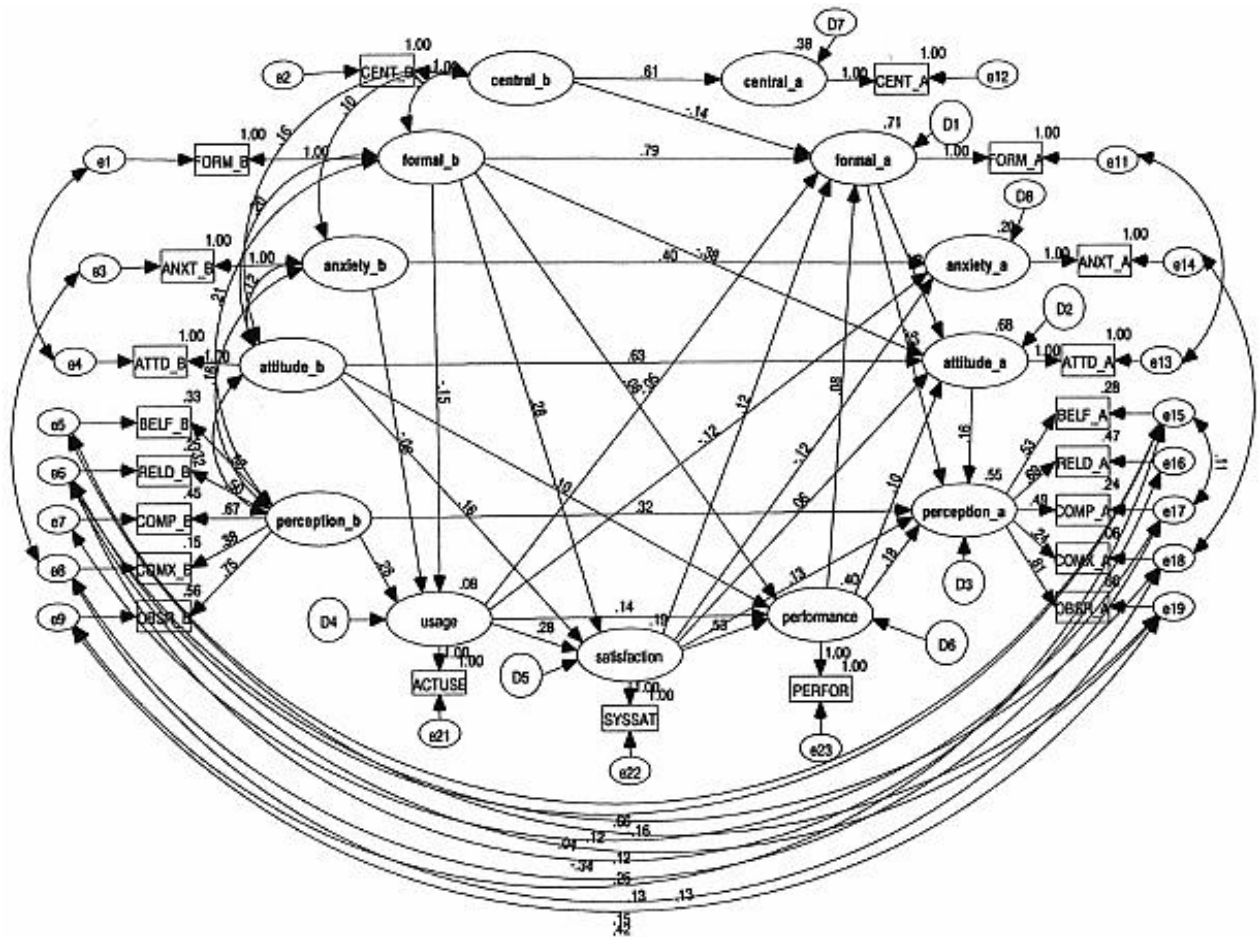

Figure 8. Combined model



**Figure 9. Higher level model**

In this model, central\_a is only influenced directly by central\_b with the path coefficient of 0.61. Formal\_a is influenced directly by formal\_b and central\_b with the path coefficients of 0.79 and -0.14 respectively and indirectly through usage, satisfaction and performance with the path coefficients of -0.05, 0.12 and 0.08 respectively. Attitude\_a is influenced directly by attitude\_b, formal\_b, and formal\_a with the standardized path coefficient of 0.63, -0.38, and 0.61 respectively and indirectly through satisfaction and performance with the path coefficients of 0.06 and 0.10 respectively. Anxiety\_a is influenced directly by anxiety\_b with the path coefficient of 0.40 and indirectly through satisfaction and usage with the path coefficients of -0.12 and -0.12. Perception\_b is influenced directly by perception\_b, formal\_a, and attitude\_a with the path coefficients of 0.32, 0.32, and 0.16 respectively and indirectly through satisfaction and performance with the path coefficients of 0.13 and 0.18 respectively. The variances explained ( $R^2$ ) for the endogenous variables are as follows: usage (0.08), satisfaction (0.19), performance (0.40), central\_a (0.38), formal\_a (0.71), attitude\_a (0.68), anxiety\_a (0.20), and perception\_a (0.55).

**CONCLUSION**

The results from this analysis provide trial models for both direct and indirect effects, three sub models, a combined model, a higher level model for predicting the change in structural dimensions, IT perceptions dimensions, and attitudinal perception both directly and indirectly through usage, satisfaction, and performance as mediating variables. The goodness of fit of these models is presented in Table 2. The partial models for direct and indirect effects do not fit the data very well. However, the three sub models, structural dimensions, IT perceptions dimensions, and

attitudinal dimensions models, and the combined model fit the data very well. Although the higher level model gives simpler explanations and fit the data reasonably well, the combined model fit the data slightly better.

**Table 2. Model Comparison**

No	Model	$\chi^2/DF$	GFI	AGFI	RMSEA
1	Direct Effects Model	7.367	0.693	0.613	0.082
2	Indirect Effects Model	5.699	0.601	0.582	0.070
3	Structural Dimensions Change Model	5.625	0.939	0.903	0.070
4	IT Perception Dimensions Change Model	4.028	0.871	0.843	0.056
5	Attitudinal Dimensions Change Model	3.212	0.942	0.923	0.048
6	Combined Model	3.353	0.960	0.925	0.050
7	Higher Level Model	5.165	0.933	0.895	0.066

The results show that formalization, centralization, belief and attitude have large coefficients in all models indicating that a small change occurred between those paired constructs. The path coefficients of observability, complexity, and anxiety indicate that they have experienced changes of medium size. The path coefficients of compatibility and relative advantage are small. These indicate that large changes occurred. Although the values are slightly different, all models provide largely consistent results. Most of the relationships recorded are due to the direct effects of the initial measures while the indirect effects through usage, satisfaction, and performance show only small influences.

In addition to this pattern of changes, the results of this study also contribute to identifying the facilitators and inhibitors for IT implementation in local government agencies of Bali. The policy experiences of the developing countries show that the government, as the leading sector, is the trend setter. Therefore, the way information technology is used in government agencies is a significant factor in national development. (Sanwal, 1991). The higher level model shows that centralization makes no contribution to the IT implementation processes. This is partly due to the fact that most of the governmental agencies in Bali are experiencing a highly similar level of centralization. Formalization has a negative effect on IT usage. This result supports the previous findings (Bingham, 1976; Lay & Guynes, 1997). In addition, it is also found in this study that the higher the degree of formalization the higher the satisfaction and performance felt by the users. Although attitudes toward change have no effect on IT usage, it is shown that attitudes have a positive relationship with user satisfaction and user performance. However, these three constructs have experienced only small changes. On the other hand, large to medium changes occurred between the paired constructs of anxiety and perception. Anxiety has a negative effect on IT usage. However, once the users use the technology and feel satisfied with the technology, they will feel less anxious. Perception has a positive effect on IT usage, and IT usage has a positive effect on user satisfaction and user performance. User satisfaction and user performance, in turn, have positive effects on perception after the implementation process.

By realizing these factors, Bali's government agencies are expected to be able to formulate better strategies in adopting and implementing IT in order to increase their service quality and productivity.

## REFERENCES

- Al-Gahtani, S.S. & King, M. (1999) Attitude, satisfaction and usage: factors contributing to each in the acceptance of information technology, *Behaviour & Information Technology*, 18(4), 277-297.
- Anderson, A.A. (1996) Predictors of Computer Anxiety and Performance in Information Systems, *Computers in Human Behavior*, 12(1), 61-77.
- Arbuckle, J. & Wothke W. (1999) *Amos 4.0 Users Guide*, Smallwater Corporation, USA
- Bailey, J. E., & Pearson, S. W. (1983) Development of a tool for measuring and analyzing computer user satisfaction, *Management Science*, 24, 530-545
- Baroudi, J.J. (1995) The impact of Role Variables on IS Personnel Work Attitudes and Intentions, *MIS Quarterly*, December, 341-355.
- Baroudi, J.J., Olson, M.H., & Ives, B. (1986) An Empirical Study of the Impact of User Involvement on System Usage and Information Satisfaction, *Communication of the ACM*, 29(3), 232-238.
- Bingham, R.D. (1976) *The Adoption of Innovation by Local Government*, Lexington Books, London.
- Cheney, P.H. & Dickson G.W. (1982) Organizational Characteristics and Information systems: An Exploratory Investigation, *Academy of Management Journal*, 25(1), 170-184.
- Cheney, P.H., Mann, R.I. & Amoroso, D.L. (1986) Organizational Factors Affecting the Success of End-User Computing, *Journal of Management Information Systems*, 3(1), 65-80.
- Cohen, J. (1992) A Power Primer, *Psychological Bulletin*, 112(1), 155-159.
- Danziger, J.N. & Kraemer, K.L. (1986) *People and Computers: The Impact of Computing on End Users in Organizations*, Columbia University Press, New York.
- DeLone, W.H. (1981) Firm Size and The Characteristics of Computer Use, *MIS Quarterly*, December, 65-77.
- DeLone, W.H., & McLean, E.R. (1992), Information System Success: The Quest for the Dependent Variable, *Information Systems Research*, 3(1), 60-95.
- Doll, W.J. & Torkzadeh, G. (1988) The Measurement of End-User Computing Satisfaction, *MIS Quarterly*, June, 259-274.
- Doll, W.J. & Torkzadeh, G. (1991) The Measurement of End-User Computing Satisfaction: Theoretical and Methodological Issues, *MIS Quarterly*, March, 5-10.
- Doll, W.J., Xia, W. & Torkzadeh, G. (1994) A Confirmatory Factor Analysis of the End-User Computing Satisfaction Instrument, *MIS Quarterly*, December, 453-461.
- Downs, G. W., Mohr, L.B. (1976). Conceptual Issues in the study of Innovation, *Administrative Science Quarterly*, v21, pp.700-714.
- Downs, G. W., Mohr, L.B. (1979). Toward a Theory of Innovation, *Administration and Society*, 10(4), 379-408.
- Ettlie, J.E. & Vellenga, D.B. (1979) The Adoption Time Period for Some Transportation Innovations, *Management Science*, 30(6), 429-443.
- Fliegel, F.C. & Kivlin, J.E. (1966) Attributes of Innovations as Factors in Diffusion, *American Journal of Sociology*, 71, 235-248.
- Gelderman, M. (1998) The Relation Between User Satisfaction, Usage of Information Systems and Performance, *Information & Management*, 34(1), 11-18.
- Goodhue, D.L. & Thompson R.L. (1995) Task-Technology Fit and Individual Performance, *MIS Quarterly*, June, 213-236
- Hage, J. & Aiken, M. (1967) Program Change and Organizational Properties: A Comparative Analysis, *American Journal of Sociology*, 72, 505-519.
- Harrison, A. W. & Rainer, R. K. (1996) General Measure of User Computing Satisfaction, *Computers in Human Behavior*, 12(1), 79-92.
- Iacovau, C.L., Benbazat, I. & Dexter, A.S. (1995) Electronic Data Interchange and Small Organizations: Adoption and Impact of Technology, *MIS Quarterly*, 19(4), 465-485.
- Ives, B., Olson, M.H. & Baroudi, J.J. (1983) The Measurement of User Information Satisfaction, *Communication of The ACM*, 26, 785-793.
- Kahen, G. (1995) Assessment of Information Technology for Developing Countries: Appropriateness, Local Constraints, IT Characteristics and Impacts, *International Journal of Applications in Technology*, 8(5/6), 325-332.
- Kim, C., Suh, K. & Lee, J. (1998) Utilization and User Satisfaction in End-User Computing: A Task Contingent Model, *Information Resources Management Journal*, 11(4), 11-24.

- Kirton, M. (1984), Adaptors, innovators and paradigm consistency, *Psychological Reports*, 57, 487-490.
- Kraemer, K.L. & Dedrick, J. (1997) Computing and Public organizations, *Journal of Public Administration Research and Theory*, 7(1), 89-113.
- Lai, V.S. & Guynes, J.L. (1997) An Assessment of the Influence of Organizational Characteristics on IT Adoption Decision: A Discriminative Approach, *IEEE Transactions on Engineering Management*, 44(2), 146-157.
- Mahmood, M.A. (1995) End User Computing Productivity: A New Approach to Help Resolve Information Technology Productivity Paradox, *Journal of End User Computing*, 7(2), 24-25.
- Moch, M.K. & Morse, E.V. (1977) Size, Centralization, and Organizational adoption of Innovations, *American Sociological Review*, 42, 716-725.
- Mohr, L.B. (1969) Determinants of Innovations in Organizations, *American Political Science Review*, 63(1), 11-126.
- Moore, G.C. & Benbasat, I. (1991) Development of an Instrument to Measure the Perceptions of Adoption an Information Technology Innovation, *Information Systems Research*, 2(3), 192-222.
- Palvia, P.C. (1996) A Model and Instrument for Measuring Small Business User Satisfaction with Information Technology, *Information & Management*, 31(3), 151-163.
- Panizzolo, R. (1998) Managing Innovations in SMEs: A Multiple Case Analysis of the Adoption and Implementation of Product and Process Design Technologies, *Small Business Economics*, 11, 25-42.
- Peterson, C.M. & Peterson, T.O. (1988) The Darkside of Office Automation: How People Resist the Introduction of Office Automation Technology in *Human Factors in Management Information Systems* by J.M. Carey (ed.), Ablex Publishing Co., Norwood, New Jersey
- Raymond, L. (1985). Organizational Characteristics and MIS Success in the Context of Small Business, *MIS Quarterly*, March, 37-52.
- Rischar, J.F. (1996) Connecting Developing Countries to the Information Technology Revolution, *SAIS Review*, Winter-Spring 1996, 93-107.
- Rogers, E.M. (1983) *Diffusion of Innovations*, 3rd ed., The Free Press, New York.
- Rogers, E.M. & Shoemaker, F.F. (1971) *Communication of Innovations*, The Free Press, New York.
- Sanwal, M. (1991) An implementation strategy for microcomputers in developing countries, *International review of Administration Sciences*, 57, 261-273.
- Sharp, C.A. (1996) *Designing Your Own Goal Attainment Measures for Evaluation*, P.E.R.S.O.N.A.L. (Research & Consultancy) Pty. Ltd., South Australia.
- Sharp, C.A. (1998) Public Sector Performance Measurement, Paper presented at the *IIR Conferences*, Perth, June
- Sekaran, U., 1992, *Research Methods for Business: A Skill-Building Approach*, 2<sup>nd</sup> ed., John Wiley & Sons, Inc., New York.
- SPSS, Inc. (1986), *SPSS User's Guide*, New York, McGraw-Hill Book Company.
- Stevens, J. (1996), *Applied Multivariate Statistics for the Social Sciences*, 3rd ed., Lawrence Erlbaum Associates, Inc., New Jersey.
- Taylor, S., & Todd, P.A., 1995, Understanding Information Technology Usage: A Test of Competing Models, *Information Systems Research*, 6(2), 144-176.
- Thompson, R. L., Higgins, C.A., & Howell, J.M. (1991). Personal Computing: Toward a Conceptual Model of Utilization, *MIS Quarterly*, March, 125-143.
- Tornatzky, L.G. & Klein, K.J. (1982) Innovation Characteristics and Innovation Adoption-Implementation: A Meta Analysis of Findings, *IEEE Transactions on Engineering Management*, 29(1), 28-45.
- Willcocks, L. (1994) Managing Information Systems in UK public administration, *Public Administration*, 72(1), 13-32.
- Woodroof, J.A.B. & Kasper, G.M. (1998) A Conceptual Development of Process and Outcome User Satisfaction, *Information Resources Management Journal*, 11(2), 37-43.
- Zaltman, G., Duncan, R. & Holbek, J. (1973) *Innovation and Organizations*, John Wiley and Sons, New York.

## What the boys are saying

---

### **An examination of the views of boys about declining rates of achievement and retention**

**Malcolm Slade**

Flinders University, Adelaide  
Malcolm.Slade@flinders.edu.au

**Faith Trent**

Flinders University, Adelaide  
adfht@post.flinders.edu.au

*This paper summarises the views of 1800 Year 9 to 11 boys about declining rates of achievement and retention. The boys have been clear and largely uniform in their perspective of the issues and problems, and in their general view that the adult world is 'not listening' and 'not really interested'. They have been equally clear about what needs to be done to effectively deal with their concerns and to provide better, more relevant educational outcomes. In brief, they see themselves to be stuck with an unsuitable, out-of-date and culturally inconsistent learning environment that they cannot change. By the middle of Year 9, their school experience has firmly established a negative and necessary association between formal learning and what they understand as an institutionalised, unpleasant waste of time, dealing with matters having no obvious relevance to their lives and their perceived needs and interests, and demanding the kind of personal sacrifice and general disempowerment that makes the hazy promise of long term rewards simply 'not enough' for most of them.*

Key words: adolescent males, achievement and retention, boys' education, boys' views, gender

### **INTRODUCTION**

The purpose of this paper has been to provide an overview of what secondary school aged boys are saying about the phenomena of declining retention and achievement, and how their educational outcomes might be improved. The paper presents the findings of a study funded through the Australian Department of Education Training and Youth Affairs', Higher Education Division, Evaluation and Investigations Program. Our primary intention has been to present the views of the boys in a way that highlights the issues and problems that they've raised and that they believe should form the focus of discussion about declining rates of retention and achievement.

### **The Adolescent Years are the Most Significant**

In brief, the boys believe that the adolescent years, from the middle of Year 8 to Year 11, are the most significant. The primary years, from reception to Year 7, are talked about as 'good times'<sup>1</sup>, when adolescent males say that they 'liked school' and 'learnt heaps of stuff'. Year 8 is said to

---

<sup>1</sup> Statements made by students are recorded in quotes and in italics.

start out *'okay, because it's all new, the work's easy and the teachers don't know you'*. The problems begin late in Year 8, continue to develop until they either *'get out'* or *'survive'* to finish Year 11 and perhaps Year 12. Our research reveals a broad range of interconnected factors that adolescent males believe make this an outcome they don't like, they don't value and that they cannot change *'because nobody's listening'*.

The adult world, for example, is not listening enough to recognize that referring to male students of secondary school age as *'adolescent males'*<sup>2</sup> is too detached, too alienating and too clinical. Of all the options, from *'adolescent males'* to *'guys'*, the participants in this study have shown a preference to be called *'boys'*. In general, this practice has been adopted in this paper.

### **Listening to the 'Boys'**

It was evident from the outset that most of the boys were clear and uniform in their perspective of the issues and problems in these years, and in their general view that declining rates of achievement and retention are inevitable because the adult world is *'not listening'* and *'not genuinely interested'* in their views, their well-being, and for many, their educational needs and outcomes:

*They don't want to listen. They make the rules. There is always an excuse. (Year 9-11)*

*They always make things sound the way they want ... what they want sound best. Ya don't stand a chance. (Year 11)*

Furthermore, the boys have obviously thought about their educational experience often and at length, and have well-formed views about a range of factors that continue to shape and direct their achievement and their ability or preparedness to remain at school.

Although the boys are not familiar with the literature, most of them have seen or heard achievement and retention issues discussed in the media. From what they have said, it is clear that they regard the views of the adult world, on these matters, to be simplistic to the point of being wrong. They believe that adults don't ask young people what they think and that they certainly don't ask in a way that establishes trust and mutual respect; they don't listen, and they don't really want to know, particularly if it requires or necessitates substantial changes on their part.

Although much of what the boys have said differs significantly from the literature, the media and what passes as *'common sense'*, these differences will not be critically examined at length in this paper. Here, it is our intention to present an overview of what the boys are saying. We have not tried to make judgements about the truth or falsity of their views, not because these are not matters of importance, but because they are of little pragmatic value until we are able to understand their views in the context of their reality. This was the essential focus and aim of the study.

To investigate matters concerning young Australians usefully, it is increasingly important to recognize that the ongoing democratisation and liberalisation of Australian society, at least in part, has been a process of understanding and accepting difference. This is not just the rhetoric of understanding and accepting difference, and not just differences of mere perspective, but the genuine recognition that there may be a different reality for others, upon which their views are based, and within which their views are equally efficacious.

---

<sup>2</sup> Statements made by people other than the students are recorded in quotes and not italicised.

There is, however, one issue that is raised in the literature and one that needs to be addressed in order to make sense of much of what the boys are saying. They are clearly very contextual, albeit not always consistently, in their understanding of the issues and problems that they believe explain the phenomena of declining retention and achievement. They include a broad range of issues and identify an equally broad range of factors, the significance of which lies as much in their dynamic interdependence as it does in their diversity, or in the particular issues or factors that they choose to talk about at length and at a particular time.

### **Going Beyond the Constraints of Our Cultural Logic**

Although poor academic achievement, or the choice to leave school early, are more easily understood as separate, isolated outcomes, they remain inseparable aspects of a plurality of interacting and compounding conditions. For example, the experiences of boys in education are varied and variable, involving a diverse range of phenomena: family environments, cultural/philosophical commitments (including some as fundamental as varied perceptions of time and space), socio-economic conditions, physiology, different school environments, teachers, activities and achievements out of school, attitudes, chance events, perceptions of success and 'the good life', the idea of what it means to be male, an adult, young, 'up to date' and many others. This diversity raises some fundamental issues about methodology, the expectation of research, and perhaps more importantly, it draws attention to the impact of the paradoxical state of the dominant cultural logic on both the problem itself and on the way it is understood (Slade & Morgan 2000).

Although it seems difficult, and perhaps impossible, to think or talk about everything in order to think or talk about something, it must be acknowledged from the outset that the dominant culture pre-disposes us to think and talk in terms of fragmentation and certainty, rather than interconnection and relativity. This is a fundamental predisposition with no less than a fundamental influence on how we understand time, space, identity, knowledge, truth and values (Spradlin & Porterfield 1984). It not only shapes our understanding of what is 'real', 'correct' and 'valuable' in education and learning, it also limits our vision of what might be done and it directs what it is that we try to do. Paradoxically, it is our success at applying fragmentation and certainty that has created both the logical and the pragmatic imperatives to think in terms of interconnection and relativity (Slade & Morgan 2000:71). Furthermore, it has created the necessity that this be done both in and through education into the twenty-first century (Delors 1998:19; Slade 1998a,1998b).

The idea that our reluctance to meet this philosophical challenge in education might itself be a large part of the problem that forms the focus of this research seems not to have been pursued to any great extent in the literature. Nonetheless, the compelling reality of interdependence is often recognized, hence the strong tendency in the literature to bring research pathways and outcomes together. However, from what the boys are saying, they have failed to come together enough.

Browne and Fletcher (1995), Kenway (1997), Epstein et al. (1998) and Collins et al. (2000), for example, see the need to bring many different approaches together in an attempt to be comprehensive. Nonetheless, these stay largely within the fields of masculinity studies and gender reform and, rightly or wrongly, inform the kinds of strategic initiatives, like the use of 'boys only' classes or 'boys' groups', that the boys in this study believe either miss the point or simply make matters worse.

Similarly, Pallotta-Chiarolli (1998) expressly emphasises the need to 'move beyond' the restrictive influence of false dichotomies like the 'either/or positioning' that sustains the 'nature

versus nurture' debate. Epstein et al. also acknowledge the need to break through this kind of restraint:

...the discourses in which debates about the schooling of boys have been framed are both narrow through the ways in which the terms 'achievement' and 'education' have been understood, and masculinist in style; that they lack historical perspective; that it is unhelpful to set up a binary opposition between the schooling of girls and that of boys, according to which if one group wins, the other loses; and that questions around equity and differences among boys and among girls as well as between boys and girls are key to understanding what is happening in schools (Pallotta-Chiarolli 1998:4).

Moving beyond the dominant cultural commitment to fragmentation and certainty is a necessary condition of dealing effectively with the issues and problems that shape and direct current changes in retention and achievement for boys.

### **IDENTIFYING THE ISSUES AND THE APPROPRIATE METHODOLOGY**

In addition to a review of the literature, a questionnaire was sent to all secondary schools in South Australia, in a bid to gauge interest in the project and to establish the issues and problems shaping changes in rates of retention and achievement for boys. This was followed by a one day conference with participating schools.

#### **The Initial Issues**

The questionnaire to schools was primarily introductory, asking only four questions:

1. What are the central issues and problems concerning and affecting the achievement and retention of adolescent males at your school?
2. What programs are in place to deal with the problems you have encountered?
3. Which initiatives are proving to be useful?
4. Would you be prepared to be part of our project, allowing us to contact you early in the new school year?

From both the literature review and the introductory questionnaire to schools it was evident that the issues and problems were being understood and treated more in terms of 'problem boys' who are not coping, than problems that boys more generally face while trying to fulfil their learning needs. The focus appeared to be largely on 'boys at risk' and the strategic emphasis on 'fixing up the boys'. This is clearly indicated in Figures 1 and 2, which graph the responses of 61 secondary schools to the first three questions in the introductory questionnaire. Figure 1 presents responses to the first question. Although poor motivation and behaviour are the two factors emphasised more than any other by the schools, most factors are identified in terms of deficiencies in the boys.

Despite the prevailing influence of a deficit model, staff in schools, through both their questionnaire responses and in subsequent discussions, expressed a general view that the incidence of problems involving boys is widespread and increasing. Furthermore, they believe that this is happening in ways that indicate a growing disaffection on the part of a broad range of boys, not all of whom fit the stereotypical boy 'at risk'. The schools, for example, draw attention both to an increasing number of 'very bright' boys who have become 'problem boys', and to an increasing number of boys in general who simply 'don't care about the consequences', either of their behaviour or their lack of interest in school work or achievement.

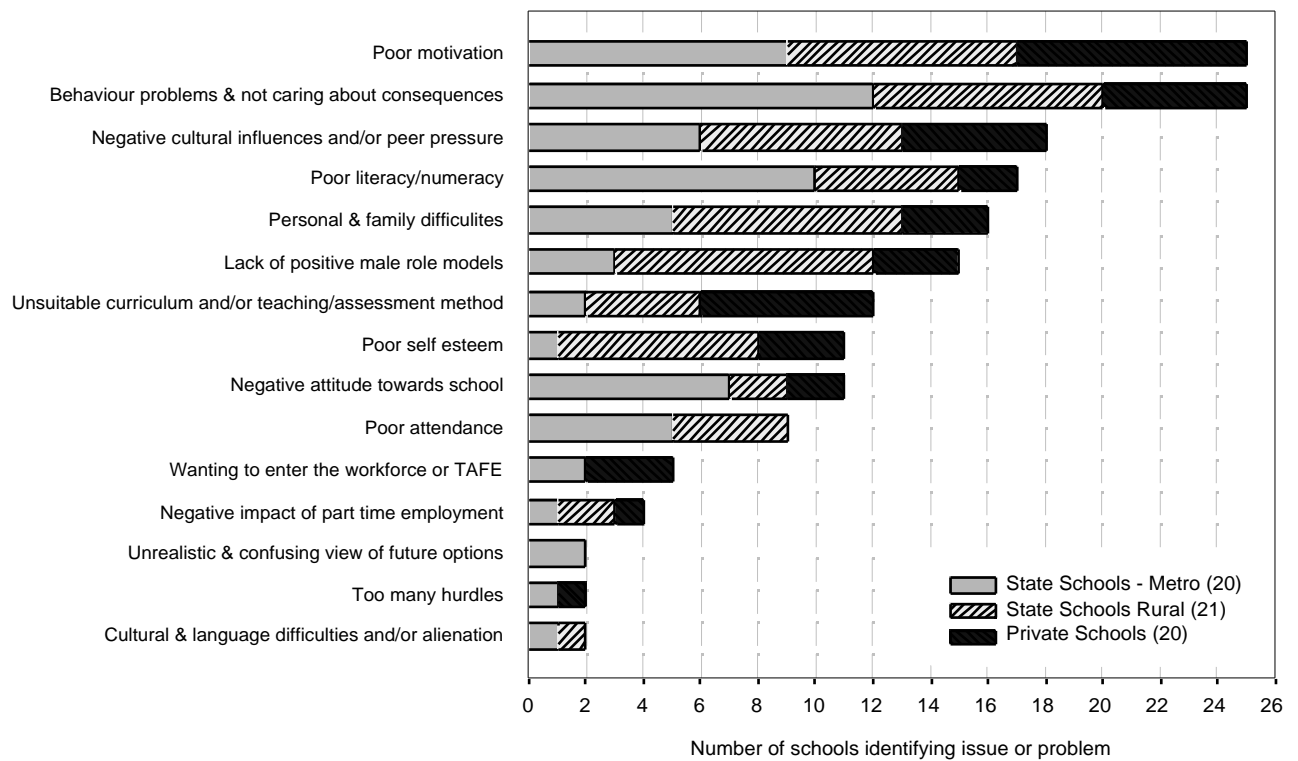
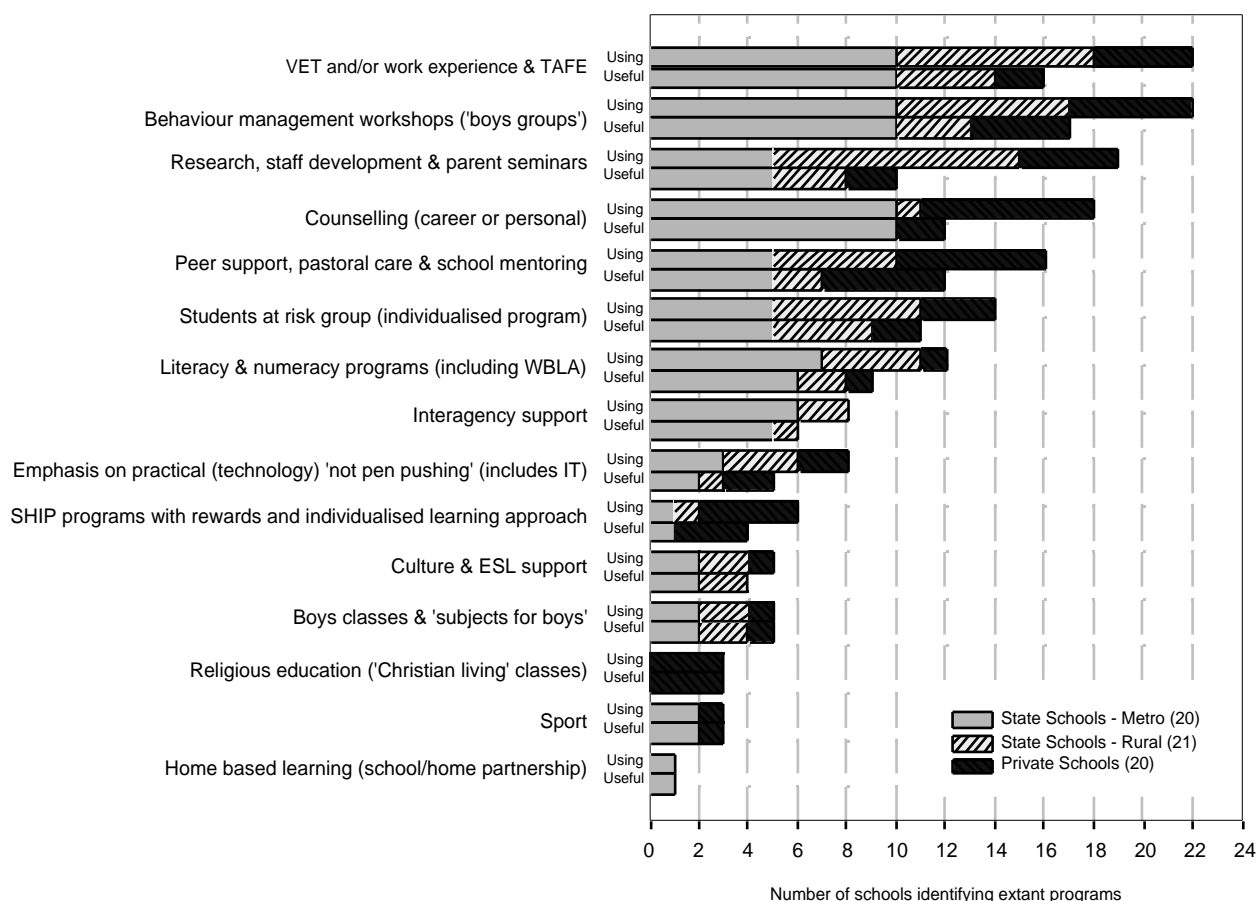

**Figure 1: Issues and problems identified by schools in the introductory questionnaire**

Figure 2 illustrates responses to Questions 2 and 3 of the introductory questionnaire to schools and indicates the programs that participating schools are currently using, the number of schools using these programs, and the extent to which the programs are considered useful.

Although the emphasis remains firmly on ‘fixing up the boys’, two points are worth noting:

1. The strategic emphasis is also upon bringing the educational experience up to date through research, staff development and parent seminars, and through the introduction or extension of vocational training, work experience and coursework done in the TAFE environment. This suggests that schools are actually responding to the issues and problems more in terms of the problems that boys face, trying to deal with an inappropriate and perhaps out of date educational offering, than might appear from their answers to Question 1 and indicated by the factors identified in Figure 1.
2. Extant programs, where these are in place, are considered useful by most schools, but not as useful as they had hoped. Most responses were cautiously optimistic, but some were more openly pessimistic, declaring that they had little confidence in the narrowness and inappropriateness of contemporary or traditional views, strategies and approaches. Several responses indicated a strong sense of debilitating hopelessness; of their sheer inability to cope with the scale and complexity of the issues and problems they felt compelled to list, when they were asked to identify the significant causal features of declining achievement and retention in boys. This was evident, for example, in schools that indicated a clear, first hand experiential awareness of declining achievement and retention in their boys, but saw themselves as having no relevant programs in place that they might genuinely call appropriate, let alone useful. Subsequent discussions with these schools revealed the presence of programs similar to those that had been identified by other schools as being used and being found to be ‘useful’ as strategies.



**Figure 2: Extant programs identified by schools in the introductory questionnaire**

More generally, the schools show a lack of confidence in the relevance and effectiveness of the kind of programs that are encouraged by current policy and research emphases. This, together with a perceived lack of resources to deal with 'one more problem', is apparent from the poor 'usefulness' given to programs involving research, staff training and community awareness, and from the relatively small number of schools electing to respond in this way.

Clearly, there is both a prevailing lack of confidence, and a diversity of viewpoints about the nature of the issues and the utility of current strategies, where these exist. Both of these demand further investigation.

Two observations are worth making which follow from this second point:

1. From what the boys are saying, they would regard the apparent lack of confidence on the part of teachers more as a lack of interest. They believe that many initiatives fail because there are too many 'bad teachers', who 'don't ask', 'don't listen', 'don't care' and who are not culturally 'up to date'. They also believe that there are too many 'old' teachers. Although 'old' teachers are not necessarily 'bad' teachers because they are old, there is a strong view that the prevalence of older teachers accounts for their lack of interest in new ideas and their cynicism about the value of established ideas and strategies.
2. Reporting back to schools, at staff meetings, training sessions, small group discussions, conferences, and parent meetings, has been a central methodological feature of this research. This has usually been done by addressing staff meetings or training sessions. Discussions at these gatherings indicate a strong interest in what the boys are saying. They also indicate a

general frustration at feeling compelled to work with policies and practices that are known to be inappropriate. They either don't know what else to do, or they feel left to pursue new and more successful directions without support, often individually, 'in secret', and against accepted practice.

Staff and parents frequently raised the point that research, similar to that being done with the boys, should be done 'back to back', involving all other groups in education, namely the girls, teachers, parents, the bureaucracy and those involved in the training of teachers. Their expressed view has been that this kind of research would not only enable a more complete picture of views and experiences, it would help to create understanding between these groups, thereby addressing one of the major problems.

### **The Emerging Issues**

Following the introductory questionnaire to schools, a one day conference was held with staff from the participating schools, at which the issues and problems were discussed and extant strategies were reviewed in more detail.

Several new issues emerged at this point:

1. The issues and problems that explain changes in the achievement and retention of boys cannot be dealt with solely in terms of gender equity, and we must avoid comparing males and females.
2. We must avoid the narrow, misleading focus on 'fixing up the boys'.
3. It is particularly important to listen genuinely to 'what the boys are saying'.
4. Given the rapid pace of social change in recent decades, together with the reality of globalisation, information technology and an aging population, there is a need to understand the influence of conflicting paradigms and the perception of inconsistency and irrelevance within the prevailing paradigm in education. There is, for example, inconsistency and irrelevance, in and between:
  - policy and practice, or the rhetoric and experience of education;
  - notions of success, achievement and appropriate behaviour;
  - prevailing expectations of education and what is actually achievable, relevant and valued;
  - the recognition, acceptance and application of changing cultural realities - including the impact of democratisation, globalisation and information technology; and
  - fundamental perceptions of space, time, identity, knowledge, truth and values, and the ways in which these are dealt with in education.

### **Appropriate Methodology**

In response to these emerging issues, a methodology was chosen that enabled us to gather the views of all boys, both those who are considered 'problem boys' or 'boys at risk', and those who appear neither to have, nor to be, problems in education. This was done in two stages. The first stage used a qualitative research method, namely, talking with 600 boys in 60 focus groups at 20 schools, selected from over sixty participating schools and balanced across all sectors.

At each school, three groups of ten boys were involved, including one group each of Year 9 and Year 11 boys, chosen at random, and one group of mixed Year 9 to 11, chosen by the school as 'boys at risk', either academically or in terms of behaviour. The focus groups met for two, ninety

minute discussion sessions. These were understood as informal discussions in which the boys were asked to discuss the reported phenomena of declining rates of achievement and retention, drawing upon their own experiences in education.

To encourage the boys to express their views freely and openly in discussion, it was agreed that no teaching staff would be present and that the views expressed would be strictly confidential. Adult participation in the focus groups was limited to the Project Research Officer, whose role was primarily to listen, and subsequently to record and summarise the views expressed.

The boys were asked to speak from their own, individual educational experience, including their perceived needs and aspirations. They were also invited to speak in the language of their choosing, and to broaden or redirect the discussion where they thought this to be necessary in order to incorporate the relevant issues and problems adequately. Their views were recorded and summarised.

At a second 90 minute session the summary of views was reported back to the boys for critical assessment, further comment, refinement, and verification.

Focus group participants willingly offered their views, showing noticeable surprise about having been asked to make meaningful comment, as well as initial caution, fearing that their comments would be held against them in some way. Soon after the start of the session, the boys demonstrated relief that they were able to offer their views in their own way, using their chosen language, and in a context that engendered mutual trust and respect. Indeed, the focus group sessions, both in terms of form and content, have been identified by the boys as examples of what might easily and productively be achieved in the classroom. Apart from comments to this effect from the participants themselves, teaching staff frequently offered feedback about the success of the groups and about the marked, positive influence that these sessions had had on the boys involved.

At the start of the sessions the boys were given an assurance of full confidentiality. In most groups, this needed to be a commitment to ensure that the discussion was only heard by the researcher. Ironically, towards the end of the sessions, the boys often asked if the tape could be played to their teachers. Although it remained agreed that it would not be, this is clearly an indication that getting the teachers to listen, in a context that involves somebody from the 'outside', and in an atmosphere of trust and mutual respect, is high on their list of priorities. It is also apparent that when boys are allowed to talk freely and to choose their own language and mode of expression, they are more enthusiastic, articulate, expressively confident and comprehensive.

Initial concerns, both about the influence of the peer group on the openness of discussion, and about the willingness of adolescent males to participate in group discussions of this kind, proved unnecessary. Although all participants were free to choose their own level of involvement, very few chose to remain silent, and even these boys appeared to express their views in ways that satisfied them. The influence of 'peer pressure' within the discussion was not apparent. Indeed, the critical climate of the discussions made it apparent that differences of viewpoint were being aired, debated and usually resolved.

In the second stage, the task of understanding 'what the boys are saying', was partly an extension of the first stage and involved talking with a further 1200 boys in 120 focus groups at the remaining 40 schools. These groups met for one 90 minute discussion only, toward the end of which they were asked to review critically the ongoing summary of what other groups had been saying.

The focus groups in the first stage had repeatedly begun with a claim by the boys that the issues and problems are not just about boys, and that *'you should be talking to girls as well'*. Some groups suggested that they *'go and get some for you now, cos they'll tell you themselves'*.

A decision was made to conduct similar focus groups, during the second stage of the project, with girls from two schools; one having a mix of rural and metropolitan students with experience in both state and private schools, and the other a senior college. The groups were selected and the discussions conducted in a way that was similar to the boys, with the only adult present being a female researcher. Although the sample was small, the aim was to do no more than trial the focus group method and test the views expressed by the boys, that the girls would identify similar issues and problems; that they would be similarly uniform in their views and largely in agreement with boys. Their responses are reported in brief.

A small selection of groups in the second stage also completed a trial Survey of Student Views, consisting of 100 statements that had been made by the boys at the first 20 schools. Although this research tool is not yet refined, the aim was to develop a list of commonly made statements about the issues and problems, in a language that *'made sense'* to the boys, and to provide a mechanism that might be used to give quantitative definition to our understanding of what they had been saying.

The second stage of the project also involved further data collection from adolescent males in their first year of tertiary study at Flinders University. Results indicate that although the pattern of attrition is becoming more severe for both sexes, the trend is greater for males.

### WHAT THE BOYS ARE SAYING: AN OVERVIEW

*I want to leave school cos it's a hole. The teachers suck, the workload sucks, homework sucks, the uniform sucks. Mum won't let me leave cos she left at Year 11 to work in a factory, sewing.* (Year 11)

*There are good things about school, but the bad things outweigh the good.* (Year 9-11)

### A Uniformity of Viewpoint

Despite the broad diversity of the sample, the boys uniformly identified a range of important factors. Although differences appeared, these remained differences of degree; largely the degree to which the issues were important in their individual experience, and the degree to which they were prepared to act individually upon their views or preferences, particularly in the light of the consequences. The boys remain clear and uniform in the identification of the issues and problems, and about the kind of changes that would improve their educational outcomes. This uniformity of viewpoint is particularly significant in four senses:

1. There was uniformity across the schools.

The boys we talked with were selected from 60 schools balanced across all sectors. Despite the apparent differences in responses from the schools the boys' views remained uniform, making it necessary to analyse and report the data on the basis of *'what the boys are saying'*.

The most noticeable differences from school to school amounted to local issues but these were largely symptomatic of views expressed in general. The views themselves were similar across all schools.

2. There was uniformity between the groups, both between the year levels and between the randomly chosen boys and those who were identified by the schools to be *'at risk'*.

Although there were understandable differences in their levels of experience, the viewpoints remained similar. Year 11 boys, for example, reflected on their Year 9 experience in ways that confirmed the views of the Year 9 participants. Similarly, the boys at risk expressed an immediate awareness of having been 'selected'. This was not resented, as much as it was used both to support their claim that teachers conspire to create, extend and maintain 'bad reputations' for boys they simply don't like, and as an indication of narrowness and inflexibility of viewpoint on the part of teaching staff. Some of these 'at risk' participants were particularly cautious at first, expressing distrust for people claiming to be interested in their views, and showing a distinct awareness of having been 'interviewed-out'.

3. There was uniformity across levels of achievement.

After visiting the first few schools, the distinct uniformity of views raised concerns about the randomness of the selection. It seemed that the schools were selecting boys who were all medium to low achievers. Given that most of the boys had spoken with some degree of disaffection, we wrongly assumed that none of them were high achievers.

In subsequent schools, after more than one hour of discussion, the boys were asked to give comment on how they were going in terms of achievement. The results were surprisingly representative of the broad range of boys in schools. Some were very high achievers and some very low. Some described themselves as 'nerdy' types who were doing well, others who were doing well but preferred to do other things and didn't really care much about school work. Some had behaviour problems but were high achievers, and there were others who kept out of trouble but just couldn't do the work, and so on. In brief, the sample was diverse and broadly representative.

Nonetheless, the simple, but significant feature of the discussions was that the boys were largely in agreement, often to the extent where one group would follow another, without having spoken to each other, and talk of the same issues, the same problems, the same people; identifying the same teachers as examples of good teachers, describing the same forms of humiliation, the same frustrations, teaching and coursework inadequacies, and so on.

4. There was methodological uniformity in the analysis and presentation of their points of view.

The boys uniformly emphasised the interconnectedness of a diversity of factors and of their constituting phenomena, drawing upon subtleties and nuances in explanation that are not apparent in the literature, nor in discussions with teaching and research staff. These appear, from the perspective of the boys, to be inaccessible to much of the adult world.

Although the understanding of both interconnectedness and the difficulty that the adult world is having in making the cultural transition from fragmentation and certainty to interconnectedness and relativity, is more intuitive and experiential for the boys, it is no less influential in their thinking and their expectations.

The last of these senses of uniformity strongly supports a conviction, repeatedly displayed by the boys, that the adult world is not listening. This needs to be understood to mean both that they don't seek, don't hear and don't respect the views of the boys. It also needs to be understood to mean that adults prefer explanations that confirm what they already think, remain uncomplicated, and make their task both straightforward and one that in the doing can be seen to be done. For the boys, this amounts to the adult world persistently getting things wrong because '*they like it simple*' and '*they just look at one thing*'. There are many examples of how this tendency has a

broad and significant influence, both on the achievement and retention of boys, and on the way that boys more generally respond to adult views and strategies.

Among the most relevant examples, are several prevailing adult views about achievement and retention for boys that turn out to be decidedly what the boys are 'not' saying.

### **What the Boys are 'Not' Saying**

#### ***It's Not that Simple***

Although the boys generally reject views and strategies that focus solely on 'fixing up the boys', they do not hesitate to see their contextually relative meaning and value. They unhesitatingly acknowledge that they are often lazy, disorganised, uncompromising, obstructive, destructive, and so on. Nonetheless, they persist in seeing these contextually, both spatially and over time. For example, they identify '*mucking up*' in class as a necessary or deliberate response to a set of circumstances that they believe cannot be dealt with in any other way. That is, these are 'necessary', retaliatory choices. We '*muck up*', they say, with '*bad teachers*' but not with '*good teachers*'. They also talk about '*being*' lazy and '*being*' disorganised because the work is boring, repetitive and irrelevant, because they dislike the teacher, and so on.

In the view of most boys, adults exclude contextual complexity in order to '*make things simple*'. This, they say, is why adults never really understand. Importantly, this is not the claim that adult views are false, it is more the claim that they are dangerously incomplete, too often to the point of becoming false in their application.

Most boys claim that they have '*got a life*' and would do a lot better at their school work if teachers took other aspects of their lives into account when setting homework, assessing a piece of work or setting deadlines:

*I've got a social life, volunteer work and sport; not just school. (Year 9-11)*

*If you don't finish your work, the school doesn't give a shit. You just get zero. (Year 9-11)*

Similarly, they say, teachers get behavioural 'problems' wrong because they don't ask how and why something happened, and with an open mind. Instead, '*they just pick on the boy with a reputation*':

*I got accused of selling drugs at school cos my friend did. Cos I knew him I got interviewed first. They accused me before anyone else, just cos of my past. I've never been involved with drugs. (Year 9-11)*

*You'll go to say your side of the story to the teacher and they'll go, 'don't answer back', or 'don't lie'. You never get to say your side. (Year 9-11)*

Teachers would understand more if they would '*just listen to you*' and recognize all of the things that are going on.

#### ***Masculinity Crisis?***

Conspicuous by its absence from their expressed views, has been the concern, evident in the literature and the media, that boys are troubled by some kind of masculinity crisis and that this influences their achievement and retention. Surprisingly, in a 90 minute discussion session, in which the boys were very open and thought themselves to have been comprehensive, there was very little discussion about any aspect of being male and its significance in education. This was even more surprising at schools where programs aimed at developing their self-awareness, self-

esteem, self-confidence and their perception of 'being male', were known to be in place and known to have involved a large number of the focus group participants.

At this stage, it appears that if there are issues and problems concerning 'being male' in education, or in society generally, most boys don't see them, or don't see them looming large in the context of issues and problems that influence their lives at school. When asked, they talk about them as issues and problems that are of interest to adults because they are mainly for and about adults.

Once again, they show puzzlement and irritation when the broad range of interconnected factors, involving bad teachers, an out of date school culture and a boring, repetitive and irrelevant curriculum, remain largely ignored while strategies, that amount to 'fixing the boys', are implemented.

It is unlikely that the boys will uniformly support any strategic initiative that is raised by teachers who they do not consider 'good teachers', and that is raised within a schooling context that shapes and directs most of the issues and problems that influence their achievement and their preparedness to finish Year 12.

### ***Literacy and Numeracy?***

Despite the emphasis placed on improving literacy and numeracy for boys, as both an explanation and a strategy to deal with declining retention and achievement, the boys in this study showed surprisingly little interest in the issue, or confidence in the strategy, remaining consistently puzzled and irritated by explanations and strategic initiatives that are directed solely at 'fixing up the boys'. It seems that for most boys, many of whom are high achievers, literacy and numeracy are valued and treated as any other aspect of the educational offering:

*If I need it, I'll learn it. If I don't, I won't.* (Year 9-11)

Once again, it would seem, that what offends boys about strategies that are intent upon 'fixing up the boys' is that, in the context of their school experience, these are seen to be the product of people who don't listen to them, don't respect their views, don't really care about their educational outcomes, and who are more intent upon finding 'quick fix' solutions, for self-interested reasons, which demand minimal change on their part.

### ***It's Not that 'It's Not Cool to be Clever'***

Another example is the boys' response to a notion (popular in the literature and the media) that boys in general think it's 'not cool to be clever'; more negatively, that they think 'it's cool to be a fool'. As a generalisation, they believe the notion to be simplistic to the point of being false.

Although most boys acknowledge that in Years 8, 9 and 10, they occasionally 'give shit to the smart people', it is thought that most of the 'paying out' that is done about cleverness, like any other kind, is done between friends, 'in fun'. It is not considered to be a significant negative influence on either their attitude to achieving or their performance at school. Furthermore, it is thought to be far less likely to occur from Year 10 onward:

*Mostly happens in Year 9.* (Year 11-12)

*If you're still here after Year 10 then you don't have to be, so you're here to do something, and if you don't then you should leave and do something else.* (Year 11-12)

Furthermore, some people 'are paid out for being dumb'. In other words, they're paid out because 'they are not smart':

*I actually see a lot of people that are not smart being paid out ... (Year 9)*

Nonetheless, some 'paying out', and some that is identified as intentionally harmful, is directed at the 'real nerds' but it is claimed that this is retaliatory and about 'social stuff'; is done in different ways, and for reasons that have little to do with cleverness or achievement. The 'real nerds', it is claimed, bring it upon themselves by being deliberately and often aggressively anti-social, sometimes to the point of being offensively elitist.

The boys see the adult interest in 'it's not cool to be clever' more as an example of how the adult world seems determined to be wrong either by taking things out of context, or by trying to understand these things without appealing to their contextual significance. Indeed, most boys believe that adults do this with agreement between themselves and with such conviction that they invent stereotypes which they all use, and which they accept without question, but which are obviously false. For the boys, this is what explains the adult interest in dealing with stereotypical boys, even when there aren't any. More particularly, it explains why adults invent the stereotypical boy who is supposed to believe that 'it's not cool to be clever':

*It's just a stupid stereotype that people have made up. (Year 11)*

*I don't think it [being clever] is uncool ... (Year 9)*

*It's cool to be clever. If you're clever then you can make more money. (Year 11)*

Rather than any tendency on the part of the boys to believe that it is not cool to be clever, it is more the impact of being misunderstood that is said to have a negative influence on achievement and retention, largely by way of creating disaffection and the belief that there are 'too many bad teachers'.

Along with bad teachers, the boys are also, but not uniformly, of the view that parents similarly misunderstand, reinforcing and extending the disaffection as well as tightening the grip of despair:

*Parents go 'you just don't want to try cos it's not cool' ...[I say] 'Mum, I'm trying but I'm getting shit marks cos I don't understand and I've asked the teacher but they just don't want to answer the question. (Year 11)*

These parents are not only involved in generating misunderstandings about matters outside of school, they compound the impact of misunderstandings inside of school by believing what teachers tell them.

This issue of trust and respect repeatedly appears in the focus group discussions. Most boys talk of the difficulty and often the impossibility of establishing a relationship of trust with adults. Interestingly, they talk of trust and respect being established between themselves, in a range of ways, some of which involve 'paying out', others are more physical, like pushing, shoving, messing up hair or clothing, and so on. They also talk of how the teachers and school rules 'get in the way' in these communicative social matters.

Indeed, one of their observations about what constitutes a good teacher, is that it is someone who understands their ways of communicating, using these to establish trust and respect. A good teacher is one who participates in these practices and enjoys the humour that distinguishes the odd incident of 'serious paying out' from general 'stuffing around'.

A good teacher, it seems, is one who is involved enough to be contextually flexible or pluralistic; someone who accepts the rhetoric of education, in practical, if not theoretical ways, particularly the importance it places on the relativity of identity, knowledge, truth and value. Notwithstanding, boys occasionally talk of the best teachers as those who are 'given shit' by

other teachers because they are flexible enough to join in with their students. Ironically, of course, this amounts to the suggestion that teachers are also involved in *'paying each other out'*, but not always in fun.

In general, the boys admire cleverness. This is one of the reasons why boys value and admire girls and the minority of boys who are high achievers, believing that their own complaints about unfair treatment take nothing away from the successes that these students are having.

### ***It's Not Just About Gender***

A final example, which is dealt with in more detail below, is the popular view that girls are getting a better deal in schools. The boys agree, but in a way that, once again, shows the popular view to be incomplete to the point of being false, largely because it separates one issue from the range of interconnected issues and phenomena that they know to be significant and know to be interconnected.

### **Factors Identified by the Boys - A Selection**

The boys identified a range of interconnected factors, emphasising the following:

- The adult world is not listening, or not genuinely listening.
- Most boys don't value school; it's more about getting credentials than learning, and these don't operate usefully as short term motives. Apart from the social life, school for most boys is considered to be an unwanted means to an end that starts out being too distant and becomes increasingly unachievable.
- Most girls get a better deal, but so do boys who find it easy or necessary to comply and conform, and who quietly get the work done.
- School work is boring, repetitive and irrelevant.
- School doesn't offer the courses that most boys want to do; largely courses and coursework that *'get you ready for a job'*.
- Homework is neglected or rejected because it is too intrusive, destructive and ultimately unachievable without sacrificing more valued aspects of their lives.
- Years 8, 9 and 10 waste too much time and the Year 11 workload is deliberately made excessive, and comes at a time when the demands of life beyond school are increasing and becoming more important, rewarding and fulfilling, e.g. part time work, sport, social life, etc.
- School pushes boys into a downward spiral of disaffection, resistance, resentment, anger and retaliation that, for many, is just too hard to stop.
- School presents too many contradictions and too many debilitating paradoxes. Some example are provided by the following:
  - School expects adult behaviour but doesn't deliver an adult environment.
  - School pushes the rhetoric of education (e.g. fairness, justice, respect, flexibility, the celebration of difference, etc.) but produces the opposite in practice.
  - School is about getting most boys out of education.

- School is about preparing you for adult life, but adult life gets in the way of school; culturally celebrated achievements and rites of passage into adult life (e.g. participation in competitive sport, getting a driver's license, owning a car, getting part time work, providing for their own needs, helping to run a household, as well as establishing an adult identity, social life and sexual relationships) are negative influences on school achievement and on the preparedness of boys to stay at school.
- The primary factor, and the most troublesome paradox for most boys, is that there are '*too many bad teachers*' who either create or exacerbate their problems, and '*too many old teachers*' who '*don't like kids*' and who '*don't stay up with things*'. Good teachers make school tolerable but there are not enough good teachers (usually said to be around ten per cent).
- For most boys, school is focused on preserving the status-quo, which makes it culturally out of date and paradigmatically inflexible. It remains detached from the real world, distant from the rest of their lives, and neither convincingly forward looking, nor plausibly concerned with the need to prepare students for a place within the emerging society.
- School is like a prison, but even prisoners get toilets they can use.

It is important to recognize that although these are the key factors raised in the focus group discussions, the boys did not offer them as a list of separate factors, each of which might usefully be understood or dealt with in isolation. Consequently, the following discussion of these factors reflects the boys' emphasis on their interconnection and their contextually conditional relevance and significance. Similarly, the boys did not give these factors a place in a static order of priority and we have tried to avoid imposing one. Notwithstanding, their relationship with '*bad teachers*' and the failure of the adult world to genuinely listen to their views, are clearly regarded as primary factors, both causally in the sense that they have an immediate influence on the significance of all other factors, and strategically in that changing one of these, at least initially, changes everything.

### GIRLS GET A BETTER DEAL

The boys uniformly and emphatically claim that girls get a better deal at school. In the classroom, the girls get more help and attention from teachers, better marks for similar work, more leniency in terms of work deadlines and behaviour, and more freedom to talk and move about:

*Girls get favoured more than boys ... (Year 9-11)*

*Yeah, I agree with that totally ... (Year 9-11)*

The boys also uniformly believe that girls are trusted more to go out of the classroom, to use the library, to work elsewhere or to use resources located in other rooms; that girls' requests to use the toilets during class time are never denied, while boys are usually told to wait, and that girls are allowed to leave the room in groups while '*they'd never let us do that*':

*If we want to go to the library ... like, if the girls ask they can go ... but we're not allowed ... they [the teachers] don't trust us ... (Year 9)*

*If the teachers see you for one minute out of class and you get suspended for it, and you haven't even done nothing wrong ... (Year 11)*

Most boys claim that they are not trusted at all; that '*girls get more excursions*' and that they occupy most of the positions of responsibility in the school because '*they are preferred by the teachers*':

*Yeah ... just little things ... like they have girls' days out and stuff like that ... (Year 9-11)*

*We don't get any of the benefits that girls get ... like excursions and things like that ... (Year 9)*

In general, the boys believe that girls are given more encouragement to stay at school, while many boys are actively discouraged; told that they are not clever, not well suited to the work, made to feel that they don't belong and that it would be in their interests to leave.

### **It's Not Simply About Gender**

Although the issue of girls getting a better deal is raised in terms of gender, it is treated more as a matter of fact; one that is considered to be well known by both boys and girls, but one, the significance of which is explicitly qualified as their discussion develops. It soon becomes evident that this is not considered to be an issue or problem that can usefully be dealt with simply in terms of gender, either as gender difference or gender equity. Indeed, it is dealt with more as an example of what they see to be the narrowness, inflexibility and general inappropriateness of most aspects of school work and school life. For example:

1. They make the point that not all girls are the same, and some girls get a better deal than others.
2. Although girls always get a better deal relative to boys, they also make the point that not all boys are the same, and some boys get a better deal than others.
3. Girls are seen to be getting a better deal as a consequence of other, more broadly significant factors; primarily that there are '*too many bad teachers*' who have '*too much power*', and that '*school is out of date*', '*too inflexible*', '*has nothing much to offer*', and too narrowly defines achievement and success. For example:
  - Bad teachers favour students who conform and comply, and allow students to benefit from '*sucking up*'. Its not so much about gender as being stuck with bad teachers and not being able to choose or move.
  - The curriculum favours students who like a particular kind of work, done in a particular kind of way. Although most boys find this to be boring, repetitive and irrelevant, the issue is not about gender as much as the lack of appropriate options and the flexibility to enable students to pursue their own learning needs and their preferred learning style and direction.
  - School neither recognizes nor values the needs and achievements of students in other aspects of their lives. It is not so much about gender as students being penalised for having a life beyond school (in many ways the kind of life that is promised as an outcome of school). The boys believe that girls '*don't have a life*' or are prevented from having a life by school work and parents. The boys feel punished for not being prepared to give up that life to meet the demands of a school system that is unnecessarily oppressive, out of date and inflexible.

Despite their uniform conviction that girls get a better deal, the emphasis of the boys' discussions is either not upon gender from the outset, or it moves away from gender, and their experience with good teachers is sufficient in itself to make this necessary. For them, this is not only compelling, it

is obvious and must be well known to all who have experienced life in the classroom, including *'the teachers'*.

From the small sample of girls' responses, it would seem that the claim made by the boys, that the girls see the issues and problems in much the same way that they do, is generally correct. Although there are gender differences in the views, there is clear, uniform agreement that the issues and problems are largely about an oppressive, inflexible, out of date offering from teachers, the curriculum, and school culture and organisation generally.

Not surprisingly, the boys are at difference with attempts, either by educational institutions, through research and the choice of corrective strategies, or by the media and the community generally, to focus solely or largely on gender equity or gender differences to explain the declining rate of achievement and retention of boys, or of boys relative to girls. Mostly, this is expressed as puzzlement; a genuine failure to understand how the adult world could make such large mistakes about the obvious. Often, it is expressed more contemptuously, as an example of the adult preference for simplistic analysis, or for the self-interested kind that draws attention away from the real issues; to avoid having to challenge the status-quo or to respond effectively to a complexity of issues at the one time, most of which require self-criticism and big changes on their part.

### **'Boys Only' Classes Just Don't Work**

From the introductory questionnaire, as well as remarks made by the boys, and by staff in several schools, it is apparent that 'boys only' classes are being used or planned as a strategy to deal with the declining achievement and retention of boys. The boys uniformly condemn the move and challenge the reasoning. In all classes other than PE, and in some cases Technical Studies, the boys believe that such a move can only make matters worse.

Although most boys are strongly of the view that girls get a better deal in the classroom, they do not believe that separating them from the girls would be an improvement. For example, if this is done on the basis of gender differences, it ignores the reality that some boys, and at some time most boys, prefer learning environments that are similar to those that would suit most girls and vice versa. In other words, by focusing narrowly on one difference, other differences are denied. It is similarly self-defeating when done in a bid to achieve gender equity. In view of their dynamic and diverse nature, the division of girls and boys into separate classrooms results in the inequitable imposition of 'equity'. Besides, girls, in girls only classes, might get an *'even better deal'*, and so on.

Interestingly, most boys believe that they work better when girls are in the classroom. This, they say, is partly because they like their company and *'they're good to look at'*, but it is also because the presence of most girls is thought to create a better, more productive and rewarding environment by providing:

- the richness of diversity;
- the asset of cleverness;
- the example of good work practice;
- a moderating influence on retaliatory behaviour;
- an interest in long term outcomes; and

- the influence of a pragmatically driven focus on compliance and conformity that results in them finding ways to make the best of a bad lot, with benefits for all.

Notwithstanding, the boys believe that the primary and most significant influence on the classroom environment is not whether or not the class consists of all boys or all girls, but whether or not it has a good teacher. The best classroom environment is one in which there is the conjunction of diversity and the kind of good teacher who is comfortable with difference and is not troubled by the riddle of relativity and its application in teaching practice.

Like compulsory sport, uniforms, and so on, it seems that gender-based favouritism or prejudice, where these are present, provide local factors that serve as instances or indicators of the more significant and somewhat general causes of declining achievement and retention.

### **‘BASICALLY, THERE ARE TOO MANY BAD TEACHERS’ - A PARADOXICAL DILEMMA FOR BOYS**

*There are definitely good teachers and bad teachers. If we could get rid of the bad teachers, we'd know who to get rid of. (Year 9)*

Despite the broad and complex association of factors, the boys consistently and emphatically see their retention and achievement problems primarily in terms of their relationship with teachers and what they see to be a proliferation of ‘bad’ teachers who are given too much power. A uniformly repeated view is that a ‘good’ teacher changes everything. One good teacher, alone, is enough to make a bad lot tolerable and achievement, in an otherwise repressive, oppressive environment, seem possible.

The participants in this study have been clear, constructive and detailed in defining the constituting features of good teaching, from their perspective; providing more than 60 defining features of a ‘good teacher’. Interestingly, their emphasis is always placed on the personality of teachers; their ability and willingness to establish relationships of mutual respect and friendship with their students. In most schools, however, less than ten per cent of their teachers were thought to meet these criteria.

A good teacher is one who:

- listens to what you have to say;
- respects you as a person; treats you like a friend; treats you as an adult;
- is relaxed, enjoys their day, and is able to laugh, especially at mistakes;
- is flexible, adjusting rules and expectations to meet the needs of individuals and particular circumstances;
- explains the work; makes the work interesting; finds interesting things to do;
- doesn't humiliate you in front of the class; doesn't try to destroy you so that you'll leave school, or tell you you're no good and that you should leave school;
- doesn't write slabs of work on the board to be copied;
- lets you talk and move about in the classroom;
- doesn't favour girls, or the boys who do what they're told;
- doesn't keep picking on people who have a reputation, pushing them to retaliate;
- doesn't mark you down because of your behaviour; and
- gives you a chance to muck up and learn from it.

The focus of discussion in all groups either starts out as, or quickly turns to, teachers. All of the boys, to varying degrees, resent what they see as largely ineffective, out of date teaching by people who they think cannot teach, shouldn't be allowed to teach, have lost interest in teaching, and who are unnecessarily, inequitably, inconsistently, and usually unsuccessfully, authoritarian.

From their remarks about good teachers, the boys are identifying teachers who go beyond the 'policies and pretence' of education and its contemporary rhetoric about thinking in terms of interdependence and relativity. Essentially, they are describing teachers who, professionally and personally, are taking risks by listening, responding, respecting, trusting and valuing their students more than the rules, the policies, the legal precedents, their training, careers, the reputation of the school, and in some cases, small but vocal groups of parents:

*Good teachers are flexible with your behaviour. You can joke in class. We drop a couple of words ... we shouldn't, but he doesn't give detentions. He breaks the rules of the school but he doesn't break his own. He's nice to you so you abide by him, we've got respect for him. (Year 11)*

Ironically, the kind of non-compliance that characterises these teachers seems to make them more successful at teaching and more valued as positive role models and often mentors:

*Whatever they do, is what we do. If they're a good teacher and they do better stuff, we do better stuff. If they are a crappy teacher, we do bad stuff. (Year 9)*

*They be good to you, you be good to them ... that's it. (Year 9-11)*

*... they are not completely strict ... no one really talks a lot and there is not a lot of telling off in the class ... Everybody seems to have respect for everyone else and there is not a lot of mucking around. (Year 11)*

*We'll get further with teachers like that ... we're motivated to work if the teacher's relaxed. It makes it fun. We want to work. (Year 9)*

*If the teacher's relaxed we're going to achieve more because we want to achieve more. (Year 9)*

Furthermore, from the boys' criteria of 'good teaching' it is evident that these teachers display a genuine, practical commitment to the democratisation and liberalisation of the young. In doing so, they are effectively offering a resolution to many of the paradoxes faced by the boys, and to the debilitating despair that ultimately shapes and directs their educational outcomes. In other words, they give them sufficient reason to believe in themselves, in others, in the value of learning and of working toward long term goals; that what needs to be done in their lives can be done, and that their confidence in the logic that led to despair was well founded:

*For a while, I thought it was just me, that I had problems or somethin'. But since I've had xxxx [a 'good' teacher] in maths, it's all changed ... everythin's better ... even other stuff ... and that was last year. I'd like to get him for everthin'. If we had him this year, I reckon I'd do real good. (Year 11)*

Although the boys often talked about the fact that they 'feel better' with good teachers, they also feel vindicated.

Interestingly, 'good teachers' might be male or female. They are not necessarily young, but it helps. Although being young does not necessarily make a teacher a 'good teacher', the boys uniformly believe that being old predisposes a teacher to be less in tune with changing attitudes, beliefs and practices, and less directed by contemporary challenges, and less focused on preparing for the future. The boys are also uniformly of the view that most of their teachers are old.

Young teachers are more likely to meet the boys' criteria for good teaching because *'they are closer to where we are'*. Young teachers are thought to like what they are doing more than most older teachers, and they *'try harder'* to *'have fun'*, and to make *'the work more interesting'*. Importantly, when the boys talk about young teachers being *'closer'*, this is not explained simply in terms of age. Young teachers are more likely to *'treat you like a friend'*, to know about *'the things we're interested in'*, and to understand the kinds of problems that school creates for young people.

More generally, young teachers are thought to be culturally more up to date; paradigmatically more in tune with the contemporary world. Not surprisingly, teachers who meet the boys' criteria for good teaching, are often thought of as *'young'* teachers, regardless of their age. Age, in itself, is not the issue. The distinguishing features of good teaching remain largely focused on the ideas, attitudes and practices of individual teachers.

### THE DOWNWARD SPIRAL OF DISAFFECTION

Once they have experienced one or two good teachers, the boys want to know why the rest can't be *'trained properly'* and why the material they teach can't be made more interesting and more relevant. To them, the logic is straightforward, that is, good teachers and good teaching are demonstrably better for all, *'so why don't they just do it'*:

*Because our teacher treated us well and everything, then everyone treated him well back. He didn't have to say be quiet all the time. Because he was so good to us we were just good back to him and we just shut up and did our work. He respected us. (Year 9)*

Given that the boys are unable to fault their logic, they seem left with the unwanted conclusion that the teachers (and perhaps most of the adult world) can't see the need for change and remain insensitive to their plight, can't change when they need to, despite the seriousness and urgency of the task, or simply don't want to change. The response from the boys to each of these is similar, namely disaffection, making resistance seem necessary, which compounds the problem, leading to resentment, anger and retaliation. The display of their response seems to be all that differs from boy to boy. For a few it is a minor irritation that is easily dealt with through compliance, but for most, the compulsion to respond, directly or indirectly, becomes an obstacle to achievement:

*We get them back and muck up with teachers that don't respect us. (Year 9)*

Despite the immediate satisfaction of being heard by way of causing disruption, the spiral of disaffection, resentment and anger is not considered by the boys to be a response that is likely to achieve a great deal. It appears to be a last resort, and perhaps a cry for help or a response driven by despair; not only the more familiar subjective *'feelings'* of despair, but a rational, objective despair. Put simply, this is the reasoned, rational conviction that what must be changed cannot be changed; that due rational process leads to this conclusion and without *'fiddling the books'* it can lead to nothing else (Medlin 1989, Slade 1989). The cheery optimism of teachers, counsellors, or perhaps parents, who say that they understand, but who offer no real solutions, merely confirms the paradox.

Objective despair logically follows from the boys' experience in education and they show very little interest in denying the logic that makes it necessary. Indeed, they seem to be determined to follow this logic at any cost. Hence, too often the spiral of disaffection is a process that they consider necessary:

*You can't just sit there. You got to fight back, muck up, or somethin'. What else can you do? (Year 9)*

Strategically, either denying their use of this logic or asking the boys to deny the logic itself, is pointless. It would be far better to give them reasons to change the outcome of the logic, for example, provide more 'good teachers'. From what the boys are saying, the prevalence of 'bad teachers' and the boys' inability to avoid or control the impact that these teachers have on their lives, remains the primary and most troublesome of the many paradoxes confronting these boys daily.

From epidemiological research findings during the last ten years we have learnt that irresolvable paradoxes of this kind can have a broad, as well as both immediate and long term, impact on human health, particularly in the formative years. Interestingly, not being able to resolve paradoxes of this kind is also thought to influence human behaviour and the ability to learn (McEwen 1998).

### **THE CURRICULUM TURNS OUT TO BE WHAT HAPPENS IN THE CLASSROOM**

For most boys, school work is boring, repetitive and irrelevant. However, from their perspective you cannot change the curriculum unless you change the teachers:

*School is, like, boring, and teachers, they are boring. (Year 9)*

Are you saying that the teachers are boring, or is it the work itself?

*No, the teachers make it boring. They rave on about stuff that is not exactly necessary. (Year 9)*

How do you think these 'boring' teachers affect your work and your achievement?

*They make us sleepy, and then you can't concentrate properly. (Year 9)*

What about the work itself?

*It depends on the teacher. Our French teacher doesn't explain anything. She, like, gives us work sheets, 'here, do that'. She just goes and sits down. We don't end up doin' it and we get duty slips. (Year 9)*

When the boys talk about both the work and teachers being boring, irrelevant and repetitive, they do this as though these were inseparable aspects of the one process that they simply call 'school'. This includes school organisation and its culture; the length of the lessons, the day, the school week, the term, and so on, as well as homework, uniforms, attendance and behaviour expectations. They include aspects of the built environment, like enclosed classrooms, toilets that can't be used, as well as gates and fences 'that make you feel like you're in prison'. They also include libraries and librarians, who they say, try to keep boys out. For the boys, these are all interdependent and causally interrelated aspects of their attitude to the work.

Nonetheless, the boys' emphasis consistently and uniformly returns to the teachers as the primary factor; the one that must be changed before any of the others can be changed; the one which by changing will change all of the others. For most boys, the fault primarily lies with the teachers, because the power lies with the teachers to make the necessary adjustments, but they don't. For them, the outcome is that boys learn less because teachers teach badly:

*You don't really learn that well if you can't concentrate because you're bored. (Year 9)*

*Teachers should do more things to make it interesting. They could do creative things instead of just sitting down filling in things on a work sheet kind of stuff. (Year 9)*

*It's the same for all lessons pretty much. (Year 9)*

It is important to note that the boys refer to the work as being boring in several ways:

1. It is inherently boring because *'it's all theory'*.
2. The work has been done before, ie, it *'is too repetitive'*.
3. The work is done in the same way, lesson after lesson, day after day, year after year, ie, we read a novel and *'do a review about it'*, then we read another novel and *'do a review about it'*, or we watch a movie and *'do a review about it'*. Sometimes *'they just get you to do assignments'* one after the other, or you just sit in classrooms and *'copy out of books or from other people'*. That's *'all we ever do'*.
4. It presents no challenge, since it's *'real easy stuff'*, and because it is easy it gets boring.
5. The work is not relevant, namely it's *'stuff you can't use'*, or *'you won't even use in the work you want to do'*, by which they mean *'real work'* outside and beyond school:

*We do real easy stuff ... we've done it all before ... it's heaps boring; it's all theory ... stuff you can't use. (Year 9)*

*I think school is too repetitive. Like in English you do the same things over and over again. We watch a movie and then go and do a review about it, then we read a book and do a review about it. That's what I get sick of doing ... (Year 9)*

*We've been doing that since Year 8 and 9 and 10 ... (Year 11)*

*I find that Year 11, (and 12 I've been told) ... that it's pointless, because you don't learn anything. They just get you to do assignments. You don't learn anything at all ... When you do assignments, you don't really care what you do, you just write it down so you can finish it ... (Year 9-11)*

*You only copy out of books or from other people, so you're not learning anything ... (Year 9-11)*

*And in maths it's just sheets [work sheets] ... (Year 9)*

*And in maths they give you things you won't even use in the work you want to do. It's pointless. (Year 11)*

*In lessons like science, languages and maths it's the same stuff rolled off again and again. (Year 9)*

*My marks in maths have dropped considerably because of the way the teachers teach. (Year 9)*

Although several subjects are talked about as inherently boring, irrelevant and repetitive, the boys consistently believe that a good teacher can make any subject interesting:

*My teacher has made a big difference in my work in maths. My mum spoke to the teacher cos she thought I was cheating. (Year 11)*

All of the boys either expressed or supported the view that they *'do better'*, in terms of self-esteem and achievement, with better teachers; they muck around less, they concentrate more, they work harder in class and they usually get the homework done.

Basically, the boys believe that by changing the teachers you have already changed the curriculum. In other words, the curriculum turns out to be what actually happens in the classroom, and learning turns out to be what the participants actually take away with them and use.

In understanding their views about the curriculum, stereotypes and other dichotomous distinctions become prohibitive and destructive. All boys say that they learn better when they are *'doing things'*; *'interesting'*, *'hands-on'* things. Nonetheless, what constitutes *'doing things'*, or things that are *'interesting'* does not fit into the more traditional dichotomous divisions between *'academic'* and *'technical'*, *'theoretical'* and *'practical'* or *'abstract'* and *'concrete'*; in which things academic, theoretical or abstract are necessarily passive and uninteresting, and things technical, practical or concrete are necessarily active, interesting and more *'real'*.

Science and maths are regarded by some boys as subjects that involve interesting, active tasks that they enjoy. Some of these are practical, but most are theoretical or abstract. The same boys speak of their interest in sport and in a range of classes involving mechanics, cooking and drama, because they amount to *'doing things'*.

Significantly, stereotypes, false dichotomies and similar culturally archival concepts, are at their most destructive in information technology, where most traditional distinctions become fuzzy. The boys, for example, fail to understand why computer games and the use of email are excluded from their academic program, why teachers spend so much time *'trying to block internet sites'* that are easily accessed from home, why teachers don't understand computers much, why they *'force students to learn what they already know'*, and why teachers and librarians stand guard over computers that have already passed their use by date.

From the views expressed by most boys, it would seem that the idea that boys and computers were *'born for each other'* needs revision. In our schools, it seems that the two might be experiencing a *'forced separation'*.

Once again, the boys bring the issue back to teachers. At schools where the Information Technology teachers are regarded as *'good teachers'* the state of the facilities, the speed of the modem, and so on, are not problems that cannot be dealt with *'somehow'*. In one school, the boys described the *'Info Tech'* teacher as *'a legend'* largely because *'he listens'*, *'he treats you like a friend'*, *'he takes you seriously'*, and he *'lets you do stuff'*. From much of what was said, it is evident that this particular teacher has understood that computing is not just a new technology, it is also a new way of life, involving new dimensions of space and time, new expectations and a virtual world in which distinctions between reality and fantasy collapse, and notions like *'distance'*, *'tomorrow'*, *'limits'*, *'restrictions'*, *'blocked sites'* and even *'copyright'* make very little sense.

Boys who talked about their ability to *'build computers'* and who have been *'programming for five years'*, or who have found ways of *'getting into blocked sites'* and so on, also talked about their frustration at being forced to do boring, menial tasks in the classroom like *'opening and closing files'* and how their resistance had led to *'withdrawal'* from computing classes and, in one case, a three day suspension. They also talked of being excluded from computing facilities because they refused to take their hats off, or because they *'used'* email or loaded *'games'* onto school computers. This general frustration is directed largely at teachers.

## STAYING ON TO YEAR 12

The spiral of disaffection is more often destructive for boys who are declared low achievers or who, more accurately, are non-achievers at school. These boys are both more prepared to accept the consequences of non-compliance and retaliation and less able to absorb these consequences in terms of the impact on their level of achievement. For them, it seems to be more important to get the immediate satisfaction of resistance and retaliation; to respond to what is perceived to be

injustice, immediately. Nonetheless, these boys generally see themselves as able to do well under the right conditions; perhaps even to Year 12 and beyond. Whatever their choice(s) of direction, they remain aware, albeit vaguely, of the advantages of completing Year 12:

*If I could leave tomorrow, get a good job, just out of the blue, there's no way I'd be here, but because of unemployment you need school - to get Year 12 and tertiary education helps a lot.*  
(Year 11)

However, most have decided that the conditions are not only not right, they are intolerable. They find themselves with no alternative other than to adjust their expectations and for many boys it seems that they view their options, in education and their career, negatively; more in terms of what they can't do. Their view of themselves; of their abilities and their potential for success, is conditioned more by the immediate circumstances of their schooling than by what they might learn or what careers they might pursue were these conditions more flexible or more suited to their needs. They seem to know that this is happening, but they feel powerless to control these events. They know that they're being assessed, and that their lives are being shaped and directed, more by the limitations of their schooling than by an objectively fair assessment of their ability and potential.

This further compounds the paradoxical dilemma of education, namely, that they have to stay in a place that they believe they can't stay in, doing work that they believe is of no value, in order to get qualifications that they believe do not accurately measure their ability, but which they will need if they are to get the chance to demonstrate their real ability to learn 'on the job'.

A surprisingly large number (perhaps more than half) of the boys say that the price of finishing Year 11 is too high. Although most of the Year 9 boys think that they could make it to Year 12, the retention figures suggest that they won't (Collins et al. 2000). Many boys have already left school before Year 11, and around half of the Year 11 boys we spoke with indicated that they would not be going on to Year 12. Many of these considered themselves unlikely to pass Year 11. The remainder thought that they would do Year 12, some because their parents wanted them to, and others because they could, and that they might need it in the future. Most of these boys felt that there was little point in going on to do tertiary study without a clear career pathway in mind. Only a small number said that they had been focused on getting good grades in Years 8, 9 and 10, as progressive steps toward finishing Year 12 with the kind of results that would lead to university study and on to their chosen career. These were usually the boys with ambitions that led to careers like 'doctor', 'lawyer' or 'engineer'.

Unfortunately, the prospect of coming back to do Year 11 or 12 at another time, for all boys, is simply rejected. Learning is synonymous with school: 'life long learning - no way!' It seems that their school experience has firmly established a negative and necessary association between formal learning and what they understand as an institutionalised, unpleasant waste of time. For them, school deals with matters having no obvious relevance to their lives and their perceived needs and interests, and demands the kind of personal sacrifice and general disempowerment that makes the hazy promise of long term rewards simply and ultimately not enough.

### **THREE VERSIONS OF A 'BETTER PLACE'**

The boys, whether they are the ones who are not achieving, who are not achieving their best, or who simply don't like the conditions under which they are being 'successful' at 'achieving', often present an idealised version of TAFE, the world of work, or senior college, as the solution to their problems. These are considered to be alternatives to school, and are usually talked about while

referring to someone who has taken one of these options. Generally, peer counselling of this kind, like peer support, peer tutoring, and peer recognition, is considered the most meaningful and reliable, albeit, not when it is ordered and organized.

Even at their worst, the possibility of pursuing TAFE, the world of work, or senior college, offers many boys genuine hope from as early as Year 9; often enough to preserve their self-esteem along with confidence in an early judgement that the world beyond school can only be better:

*Compare this school to xxxx [a private senior college for Years 11 and 12] ... I reckon all schools should be like that ... you choose what time you have your lessons and all that ... it makes school easier and it makes you want to work. (Year 9)*

*TAFE would be better cos it's more focused on one thing. Here [at school], you have to do all these subjects and it doesn't sink in properly. (Year 11)*

*With work, you have more motivation ... it will be better ... you get paid. (Year 9-11)*

Whether or not the boys are getting accurate reports about TAFE, the world of work or senior college, is not the most important issue. These alternatives, and the way the boys describe them in their discussions, provide us with models of what they see to be better learning environments; options that they would like to pursue and that they believe would effectively deal with all of their current problems. As alternative models of a better place, these options provide templates for change in schools, and basically, they are templates for adult learning environments.

Of course for some boys at least one of these options has already been realised, and with great satisfaction. For example:

1. The majority of the boys involved in this study have experienced the world of work through part time jobs by the time they reach Year 11. Many understand these part time jobs to involve very poor pay and working conditions. Nonetheless, work remains a better place; one that offers the status and experience of adult life, and 'you get paid'. Although part time work becomes a major obstacle to their achievement and retention at school, it is paradoxically an effective antidote for the kind of dissatisfaction that they believe explains poor achievement and retention outcomes.
2. From what the boys are saying, vocational education works far better when they are allowed to leave the school to attend courses at a TAFE centre. Although they talk broadly and favourably about the benefits of having a more adult learning environment at TAFE, with better teachers and more interesting, useful work, for many boys it is a transforming influence on their lives and their attitude to learning because it solves their problems with schooling and leaves them feeling vindicated; life beyond school is better, and learning can be interesting and useful. Paradoxically, although these boys were encouraged to take up TAFE courses because of their poor performance in more academic areas, one of the outcomes they identify is a higher level of achievement and retention in those areas:

*TAFE is better cos they treat you different to school. More like an adult. (Year 11)*

*Yeah, the TAFE teachers treat you more like mates. (Year 11)*

*At TAFE there is better material and equipment, we do prac and theory, but at school it's all theory. (Year 11)*

*School expects you to do it [school work] at the weekend, but TAFE realises that you need time to relax. (Year 11)*

*TAFE is much better cos everyone wants to learn, so you do heaps more. It's heaps more interesting. (Year 11)*

*Cos of TAFE we get a free lesson [at school], which helps with the work [homework]. (Year 11)*

Of all the groups of boys in this study, only two were uniformly content with their current educational offering. One was a group of boys at risk, all of whom were in Year 11, and most of whom were attending a TAFE college one full day each week. The other was at a private senior college, catering solely for Year 11 and 12 students.

3. The senior college experience gave the boys a more adult learning environment, with a culturally more up to date 'atmosphere', but the focus of their satisfaction repeatedly returned to the improved relationship they have with their teachers:

*The atmosphere here makes the difference. Everyone wants to learn, and wants to go to uni'. Everyone generally gets along with everyone else ... the relationship between teachers and kids. (Year 11)*

*There's more trust. At my old school you had to have a note from your parents for everything. Here, you can leave the campus if you want. They treat you more like adults. (Year 11)*

*At the old school you were forced to do your homework. Here, they're not forcing you but if you don't do it you're only letting yourself down. Everyone is still doing it [the homework]! (Year 11)*

*If you respect the teachers ... they are not completely strict ... no one really talks a lot and there is not a lot of telling off in the class. Compared to last year, like, I went to the same school for eight years, they're just constant with 'keep quiet', 'shut-up'. It's a constant thing. Like, here, it might come up once or twice in a lesson, and it's just, 'could you please be quiet', Everybody seems to have respect for everyone else and there is not a lot of mucking around. (Year 11)*

It is important to note that the boys see a distinction between adult learning environments, either idealised or experienced, and their current 'senior school' offering. From the experience of the boys in this study, most senior schools, despite their diverse and changing nature, remain schools. For most boys, they offer improved environments but these remain little more than minor concessions, and even these are thought to be largely to the benefit of those who make it to Year 12 by learning to fit into an environment that has not sufficiently recognized their age, their cultural expectations and their current life style preferences. By contrast, adult learning environments offer the full recognition of 'adulthood'.

It is also important to understand their use of the term 'adult'. Being 'adult' is partly a measure of maturity in years, but it is far more a justification for being treated fairly and equally as individuals in their own right; applying the same conditions of respect, justice, equity, fairness, freedom, responsibility and so on, that are usually denied to children 'because they are children':

*... like, one of my mates had, like, a beard, and he's been told off by the teacher, and it's an expectation of the school to shave it off ... It was a clean shaved beard ... It didn't have this morning's corn flakes in it or anything ... It looked good and they told him to go away. (Year 11)*

*We get caned [not physically] for having facial hair at school, these days.*

*Teachers are allowed to have facial hair. See, what's that?*

*... but the thing is the feeling there ... Teachers should have to live by the same expectations as us.*

*Yeah, instead of treating us like kids. (Year 11)*

Interestingly, a large part of what is generally meant by the term 'maturity' is a preparedness to conform and to comply to the expectations of 'adults'. The boys don't use this term a great deal, but when they do, it is usually used to explain the success of girls and the 'approval' afforded to them by the adult world.

Although the three preferred options of TAFE, the world of work, or senior college, are expressed as idealisations, they are common in that at least one of them will be seen to offer each of the boys, despite their diversity of backgrounds, abilities and interests, a way of getting out of oppressive, restrictive school environments that are seen to be out of date and dominated by bad teachers who prefer to establish control rather than mutual trust, respect and a place 'with' their students in the process of learning.

The boys talk about TAFE and senior college as educational alternatives offering better teachers, more flexibility, more freedom, and where the students are treated with more respect and more generally, as adults. The world of work is seen in a similar way. It offers more interesting tasks, less pressure, more real learning opportunities, more respect, freedom, an adult identity and immediate rewards; recognisable rewards, namely money and the adult lifestyle that it can buy.

### **THE PARADOX OF ACHIEVEMENT: THE UNRECOGNISED CV**

From what the boys are saying, it seems that at Year 11 most of them have achieved a great deal. They are very perceptive, intelligent young men who are struggling to believe in themselves and surviving conditions that would destroy most adults. At Year 11, and at about 16 to 17 years of age, these boys have an impressive curriculum vitae; one that must make any researcher wonder why you're asking them to focus on their declining rate of achievement.

The boys seem to be aware of their achievements, and aware that the adult world, particularly the world of education, affords them little or no recognition. In its place, they find themselves systematically excluded from being seen to be achievers.

Although the boys show an awareness that success means different things for different people, they are puzzled, disappointed, and in many cases angry, that the adult world persistently fails to recognize their successes, particularly those that, in contemporary Australian society, are clearly 'rites of passage' into adulthood. For example:

- They have found and sustained part time work, and at a time of high unemployment. In excess of 60 per cent of the Year 11 boys say they are working, with the average being around 15 hours - in some groups all the boys were working and some are working 25 to 35 hours a week in low paid jobs with difficult conditions and often have supervisory responsibilities.
- Many Year 11 boys are licensed car drivers.
- They have managed to maintain, for over three years, their involvement in an education process that they believe to be unsuitable and often hostile to their needs and interests.
- They participate in some sort of competitive sport, whether it be in organised team sports or in more individual pursuits like skate-boarding. More than 60 per cent indicated a weekly commitment to organised team sports, in the range of 6 to 12 hours, spread over 2 to 5 days each week.
- They maintain a social life with both male and female friends.
- They make difficult decisions, for example, about drug use.

- They deal with family differences and problems, some of which produce pressure to achieve in particular ways or conditions that shape and direct education options, performance and outcomes.
- They continue to adjust to rapid physiological and psychological changes.
- They cope with the increased responsibilities of adulthood, while being actively denied the accompanying adult freedom and empowerment.
- They sustain a fundamental belief in their culture, expressing this through their individual integrity, their passion for freedom, and their strength to resist perceived injustice against all odds.
- They are surviving an advertising industry that makes promises that it cannot deliver, and popularises goals and 'norms' that cannot be realised.
- They remain forward looking and largely optimistic, despite being taught about the horrors of converging social and environmental crises which threaten human survival on a global scale.

Despite these and other positive achievements, the boys find that they get very little recognition for their successes; recognition coming mostly from their peers. Few rewards are given and their gains have little or no impact on their school grades. Furthermore, the boys find themselves judged by their teachers, the school, and often parents, as being 'failures', 'poor achievers' or just not being capable of applying themselves to difficult tasks.

It would come as no surprise to the boys to learn that the focus of the literature and the media, when dealing with the declining rates of retention and achievement, is essentially directed toward 'fixing up the boys'. It would come as even less of a surprise to learn that the character of responses, from our introductory questionnaire of participating schools, was similarly directed at 'fixing up the boys'. It would seem that the boys themselves see their problems very differently.

They see themselves stuck with an unsuitable learning environment that they cannot change, largely because it is constituted by teachers who don't care. Although they identify the curriculum as irrelevant and unchallenging, their experience with 'good' teachers has shown this to be an unnecessary outcome. Furthermore, it is one that is made worse because it is dominated by authoritarian school policies and practices that achieve nothing other than wasting classroom time, making education an unpleasant experience, and creating a pre-occupying focus on getting out of school as soon as possible. Once again, their experience with 'good' teachers has shown them that this is also an unnecessary outcome.

The choice, whether or not to correct declining rates of retention and achievement, they believe, lies largely with the teachers and the preparedness of an aging adult world to '*genuinely listen*', and to '*catch up*'; to bring the culture and focus of schooling up to date so that it might be better placed to keep pace with the economic, social and cultural changes that are already making demands that it cannot meet, and that in the coming decades will be as much dramatic as they are inevitable.

## REFERENCES

- Barton, A. & Lazarsfield, P. (1969) Some functions of qualitative analysis. In G. Macall & J. Simmons (eds). *Issues in Participant Observation*. Reading: Addison-Wesley.
- Browne, R. & Fletcher, R. (1995) Introduction. In R. Browne & R. Fletcher (eds). *Boys in Schools: Addressing the Real Issues*. Sydney: Finch Publishing.
- Collins, C., Kenway, J. & McLeod, J. (2000) *Factors Influencing the Educational Performance of Males and Females in School and their Initial Destinations after Leaving School*. Canberra: Commonwealth Department of Education, Training and Youth Affairs, Analysis and Equity Branch.
- Delors, J. (Chair). (1996) *Learning: the Treasure Within*. Report to UNESCO of the International Committee on Education for the Twenty-first Century. Paris: UNESCO.
- Epstein, D., Elwood, J., Hey, V. & Maw, J. (1998) Schoolboy frictions: Feminism and 'failing' boys'. In D. Epstein (ed). *Failing Boys?: Issues in Gender and Achievement*. Buckingham: Open University Press.
- Kenway, J. (1997) Boys' education, masculinity and gender reform: Some introductory remarks. In J. Kenway (ed). *Will Boys be Boys: Boys' Education in the Context of Gender Reform*. Deakin West ACT: Australian Curriculum Studies Association.
- McEwen, B. (1998) Protective and damaging effects of stress mediators. *The New England Journal of Medicine*, 338 (3), 171-179.
- Medlin, B. (1989) Objective despair: How to beat it. In T. Dendy, (ed). *Greenhouse '88: Planning for climate change*. Adelaide: Department of Environment and Planning.
- Pallotta-Chiarolli, M. (1997) We want to address boys' education but... In J. Kenway (ed). *Will Boys be Boys: Boys' Education in the Context of Gender Reform*. Deakin West ACT: Australian Curriculum Studies Association.
- Slade, M. (1989) Social, economic and political response to the greenhouse problem. In T. Dendy, (ed) *Greenhouse '88: Planning for Climatic Change*, Adelaide: Department of Environment and Planning.
- Slade, M. (1998a) Developing a fundamental commitment to global interdependence and cultural pluralism: Learning within the world culture. Paper presented at UNESCO Asia-Pacific Conference on Education for the Twenty-first Century, 1998, Melbourne. [Online] Available at: <http://wwwed.sturt.flinders.edu.au/fuiie/confpapr/malcolm1.html> [1998, August]
- Slade, M. (1998b) The philosophical challenge and its place in the education strategy. Paper presented at UNESCO Asia-Pacific Conference on Education for the Twenty-first Century, 1998, Melbourne. [Online] Available at: <http://wwwed.sturt.flinders.edu.au/fuiie/confpapr/malcolm2.html> [1998, August]
- Slade, M. & Morgan, D. (2000) Aboriginal philosophy in Australian higher education: Its own place in its own time. In G. R. Teasdale & Z. Ma Rhea (eds). *Local Knowledge and Wisdom in Higher Education*. Oxford, England: Pergamon.
- Spradlin, W. W. & Porterfield, P. B. (1984) *The Search for Certainty*. New York: Springer-Verlag.